

2A

På kryds og tværs

A	H		B	
2	3		4	9
	C			
	4	0	0	
D			E	I
1	0		3	1
		J		
8		9		6
	F		K	
	1	1	5	
G			L	
2	1		5	2

Vandret →

- A: $10 + 13$
- B: $41 + 8$
- C: Efter 399
- D: $5 + 5$
- E: $20 + 11$
- F: $116 - 1$
- G: $7 + 7 + 7$
- L: $55 - 3$

Lodret ↓

- B: $400 + 3$
- D: $6 + 6 + 6$
- F: $6 + 5$
- H: Efter 339
- I: $8 + 8$
- J: Før 92
- K: $50 + 5$



A	H		B	
4	2		2	8
	C			
	5	0	0	
D			E	I
5	0		8	2
		J		
8		8		5
	F		K	
	4	0	9	
G			L	
7	5		6	6

Vandret →

Eleverne finder selv på regnestykker

- A: _____
- B: _____
- B: _____
- D: _____
- C: _____
- F: _____
- D: _____
- H: _____
- E: _____
- I: _____
- F: _____
- J: _____
- G: _____
- K: _____
- L: _____

Hvor mange er der?

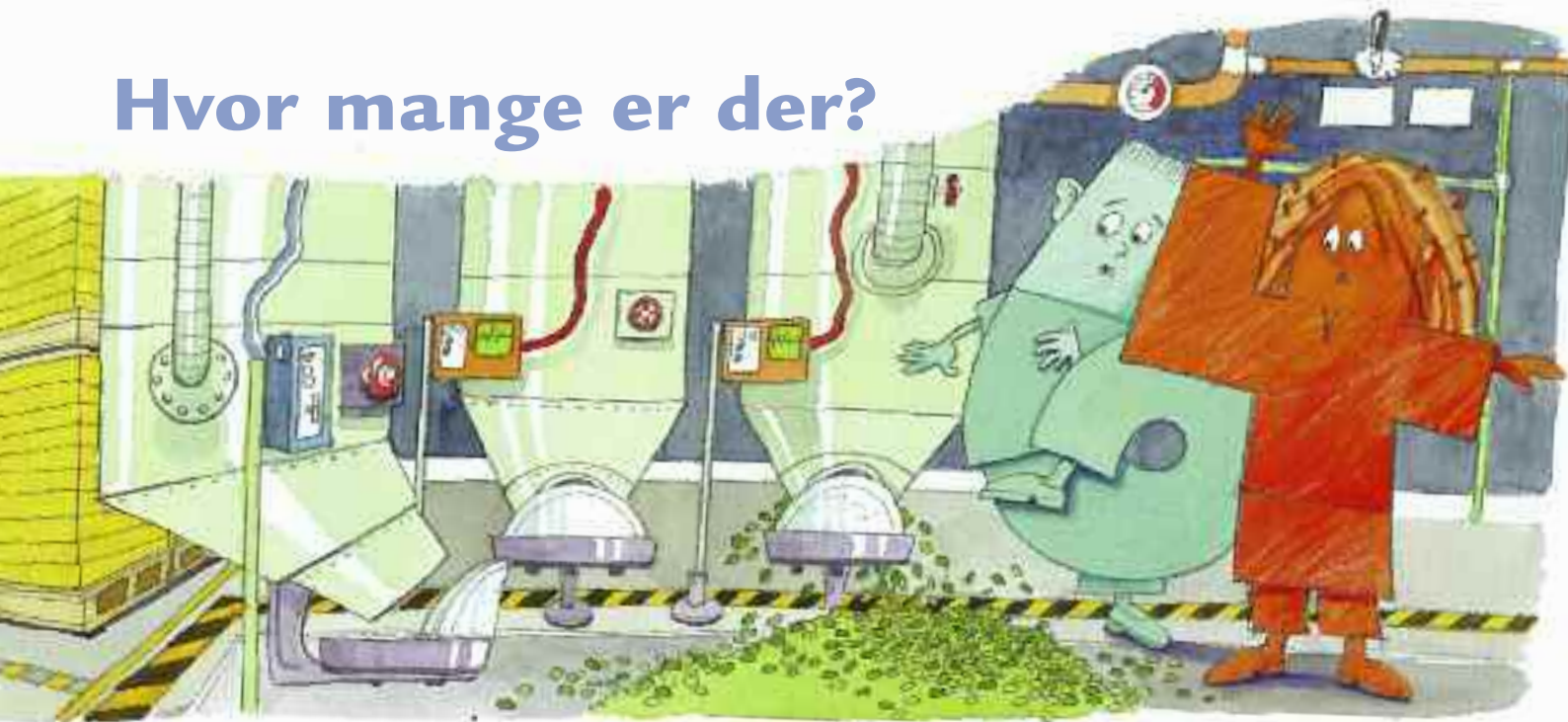

1 knap



10 knapper



100 knapper

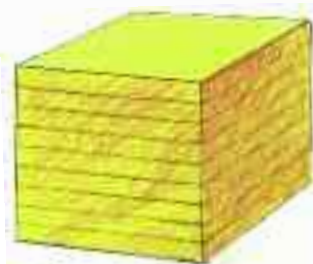









1000 knapper

1

Hvor mange knapper?









<p>50</p>	<p>200</p>	<p>500</p>	<p>1000</p>
<p>60</p>	<p>3000</p>	<p>900</p>	<p>8000</p>

	= 3		=	3000
	= 2		=	200
	= 5		=	50
	= 4		=	4







2

Hvor mange knapper?

3  = <u>30</u>	1  = <u>100</u>	2  = <u>200</u>
9  = <u>90</u>	5  = <u>500</u>	8  = <u>8000</u>
<u> </u>  = <u>50</u>	<u> </u>  = <u>700</u>	<u> </u>  = <u>4000</u>

3

Knapper i alt

				Knapper i alt
7	5			7500
	4	3	8	438
	1	9		190
5	8			5800
	9		2	902
	3	6		360
3		4	1	3041
4	6		7	4607
2		1	8	2018

Hvor mange?

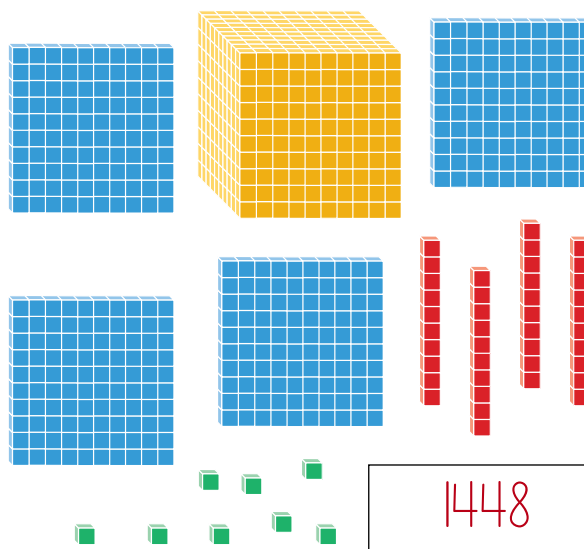
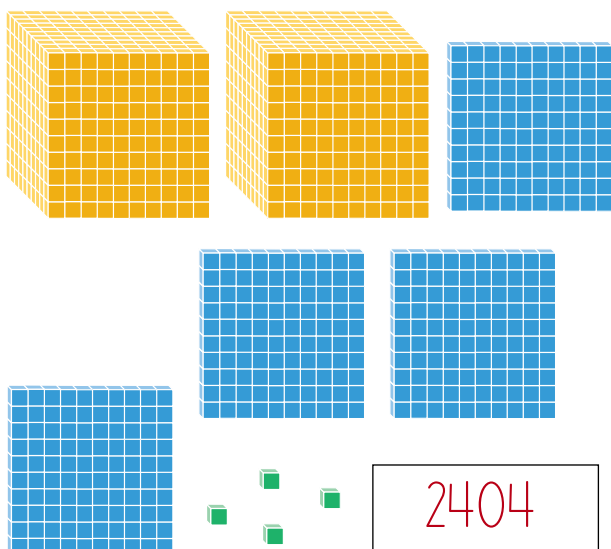
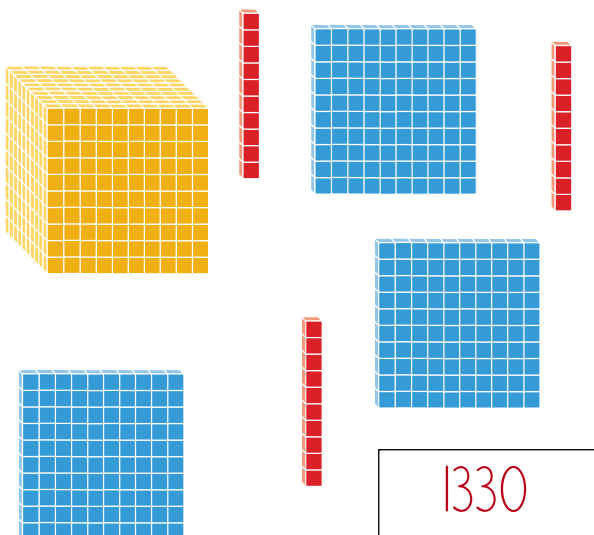
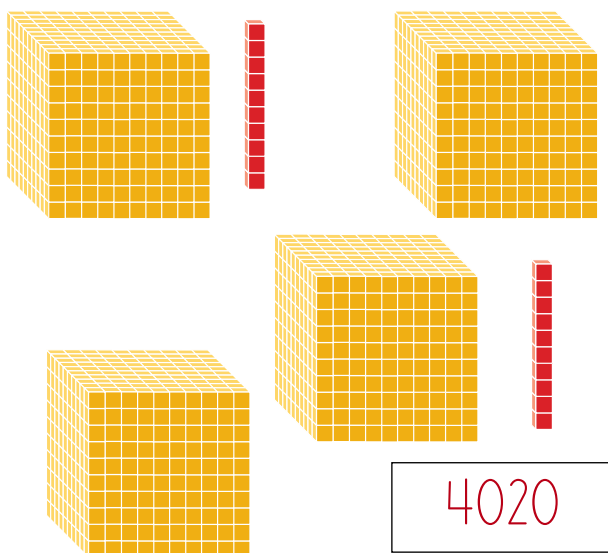
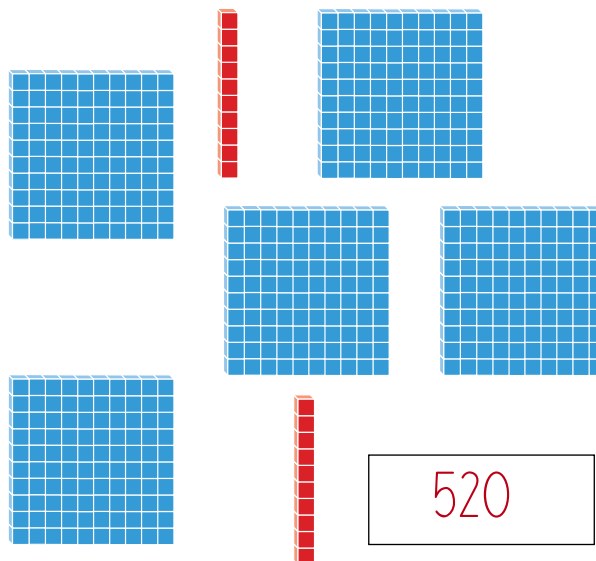
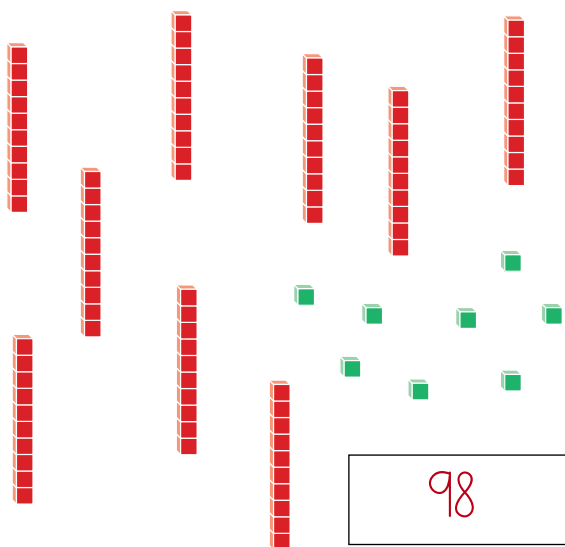

5

Hvor mange penge?

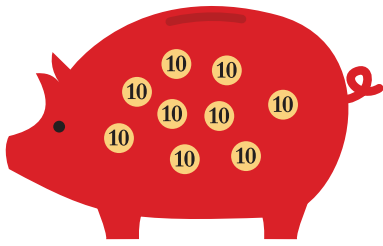
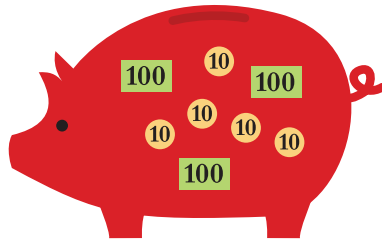
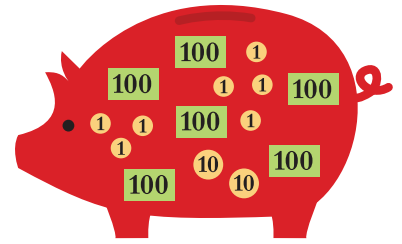
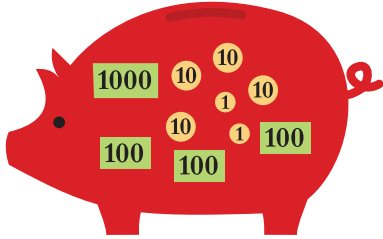
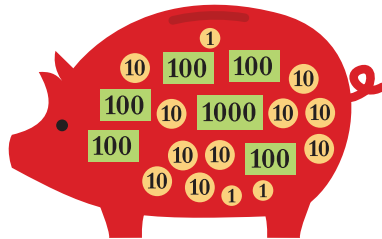
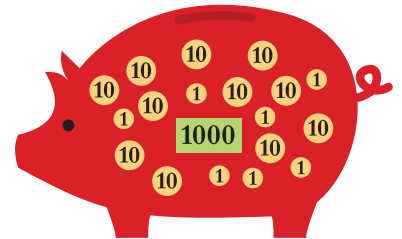
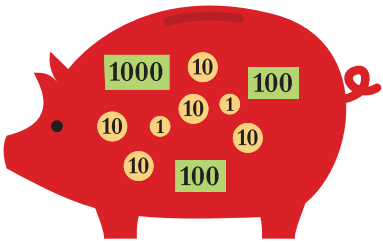
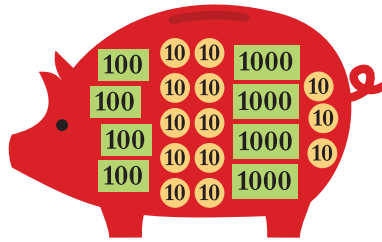
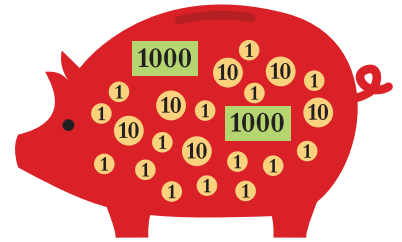
I alt 90 kr.I alt 350 kr.I alt 627 kr.I alt 1342 kr.I alt 1603 kr.I alt 1117 kr.I alt 1252 kr.I alt 4530 kr.I alt 2075 kr.

6

Del op i 10'ere og 100'er

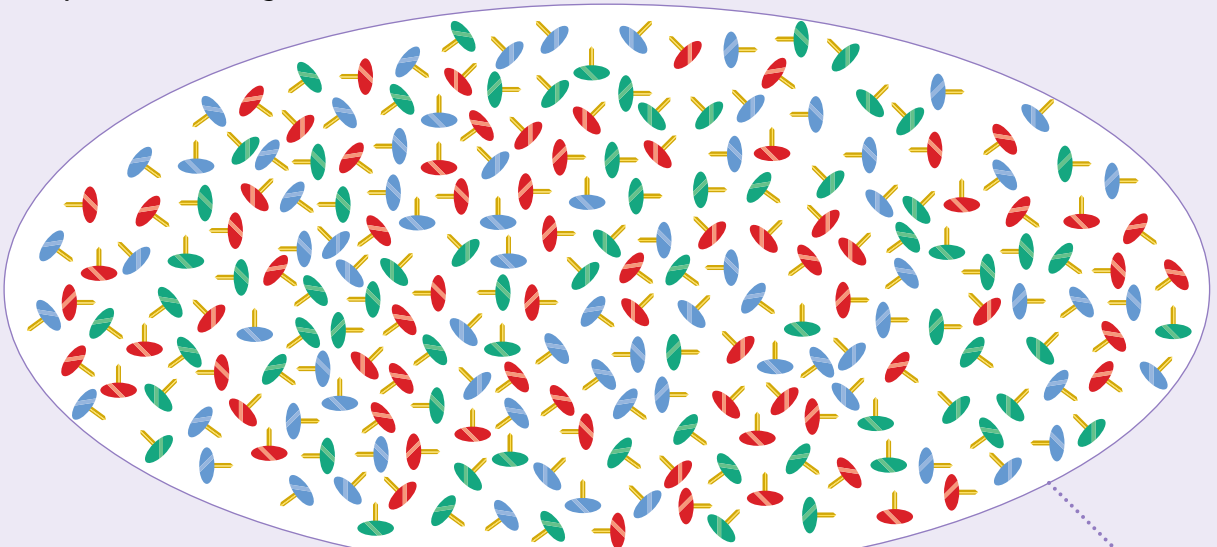

225

5. Tæl pengene og skriv antal kroner i alt.
6. Tæl og bundt i 10'ere og 100'er. Skriv det samlede antal.

7

Skriv tal

210	211	212	213	214	215	216	217	218	219
200	201	202	203	204	205	206	207	208	209
190	191	192	193	194	195	196	197	198	199
180	181	182	183	184	185	186	187	188	189
170	171	172	173	174	175	176	177	178	179

8

Skriv tallet

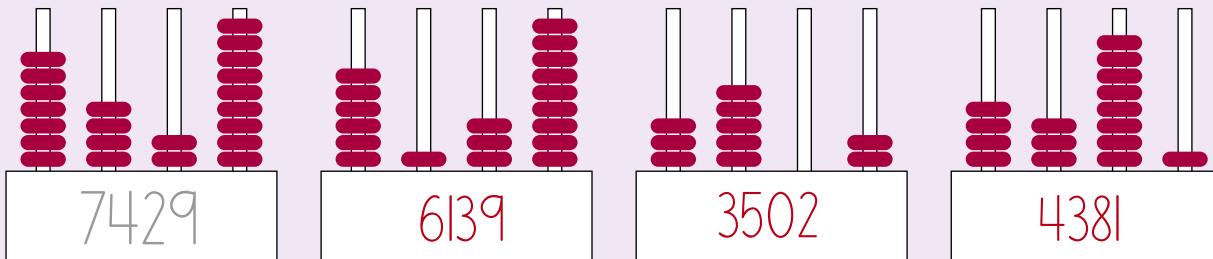

9

Vis tallet

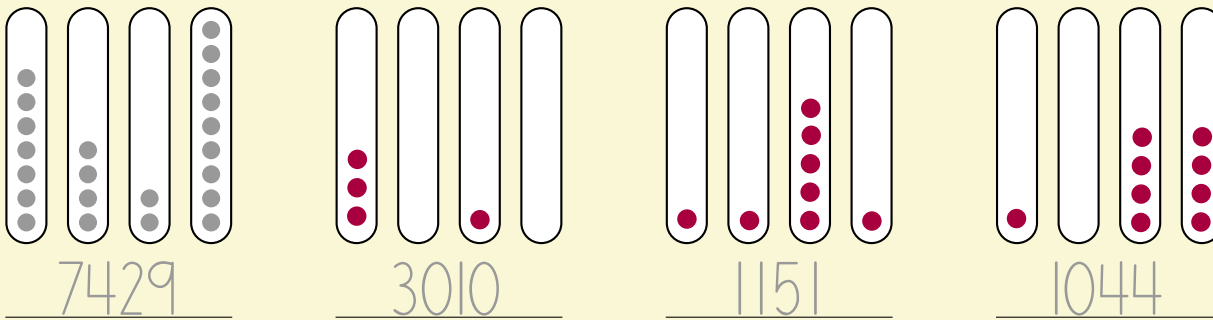

10

Skriv 12 tal i rækkefølge. Brug **1** **4** **7** **8** Flere løsninger

1. 844 4. _____ 7. _____ 10. _____
2. _____ 5. _____ 8. _____ 11. _____
3. _____ 6. _____ 9. _____ 12. _____

11

Hvor mange penge?

286 kr.

3639 kr.

5107 kr.

6143 kr.

1332 kr.

3195 kr.

12

Sæt prikker og skriv point

2659

6083

3545

7804

4798

5307







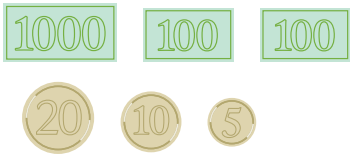

8016

1930

11. Bundt pengene og skriv det samlede beløb.
12. Sæt prikker og skriv point.

13

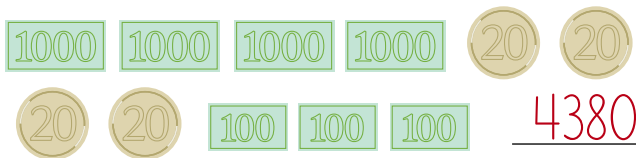
Hvor mange penge?

Du har	Du får	Du har nu
 <u>1235</u> kr.		<u>1335</u> kr.
 <u>1070</u> kr.		<u>1470</u> kr.
 <u>700</u> kr.		<u>1200</u> kr.
 <u>4380</u> kr.		<u>4500</u> kr.

14

Hvad sker der med tallet?

	+ 1	+ 10	+ 100	+ 1000
4783	4784	4793	4883	5783
2126	2127	2136	2226	3126
4561	4562	4571	4661	5561
3418	3419	3428	3518	4418
7655	7656	7665	7755	8655
5347	5348	5357	5447	6347
1000	1001	1010	1100	2000

15

Hvad sker der med tallet?

	- 1	- 10	- 100	- 1000
2544	2543	2534	2444	1544
4783	4782	4773	4683	3783
2126	2125	2116	2026	1126
4561	4560	4551	4461	3561
3418	3417	3408	3318	2418
7655	7654	7645	7555	6655
5347	5346	5337	5247	4347

16

Skriv tallet. Skriv plus eller minus

128 $\boxed{+}$ <u>200</u> = 328	456 $\boxed{-}$ <u>300</u> = 156
789 $\boxed{+}$ <u>2000</u> = 2789	105 $\boxed{+}$ <u>1000</u> = 1105
5462 $\boxed{-}$ <u>5000</u> = 462	52 $\boxed{+}$ <u>2300</u> = 2352
838 $\boxed{+}$ <u>1000</u> = 1838	4000 $\boxed{-}$ <u>2000</u> = 2000
1500 $\boxed{+}$ <u>1300</u> = 2800	614 $\boxed{-}$ <u>114</u> = 500
4037 $\boxed{-}$ <u>3007</u> = 1030	3318 $\boxed{+}$ <u>3300</u> = 6618
2378 $\boxed{+}$ <u>4020</u> = 6398	7938 $\boxed{-}$ <u>908</u> = 7030
3999 $\boxed{-}$ <u>3500</u> = 499	2563 $\boxed{+}$ <u>3020</u> = 5583
6741 $\boxed{-}$ <u>1500</u> = 5241	1234 $\boxed{+}$ <u>4444</u> = 5678

15. Regn minusstykkerne, og skriv resultatet.

16. Skriv tal og fortegn så det passer.

26	27	28	29	30	31	32	33	34	35	36	37
----	----	----	----	----	----	----	----	----	----	----	----

11

Hvad er mønterne værd?



1

Hvilke mønter betaler du med? Eksempelvis som her:



10
25



25
50



10 25
5



10 2
2 50



10 2
5 25 50



5 25

2

Afrund til kroner



10 kr.



1 kr.



15 kr.



15 kr.



20 kr.



5 kr.

3

Køb tre ting

for højest 30 kr.

Eleverne vælger selv 3 ting

De to billigste ting

Fiskekrog, tennisbold

De to dyreste ting

Sokker, blink

4

Hvad koster tingene tilsammen?



cirka **30** kr.
eller 30,75 kr.



cirka **21** kr.
eller 20,50 kr.



cirka **36** kr.
eller 35 kr.

5

Hvor mange kroner?



2 kr.



4 kr.



5 kr.



4 kr.

3. Køb tre ting for højest 30 kr., og skriv dem. Skriv også de to billigste og de to dyreste.
 4. Regn ud, hvor meget de tre ting koster tilsammen. Regn enten med de præcise eller de afrundede beløb.
 5. Tæl mønter og skriv antal kroner.

6

Sæt streg til nærmeste 10'er

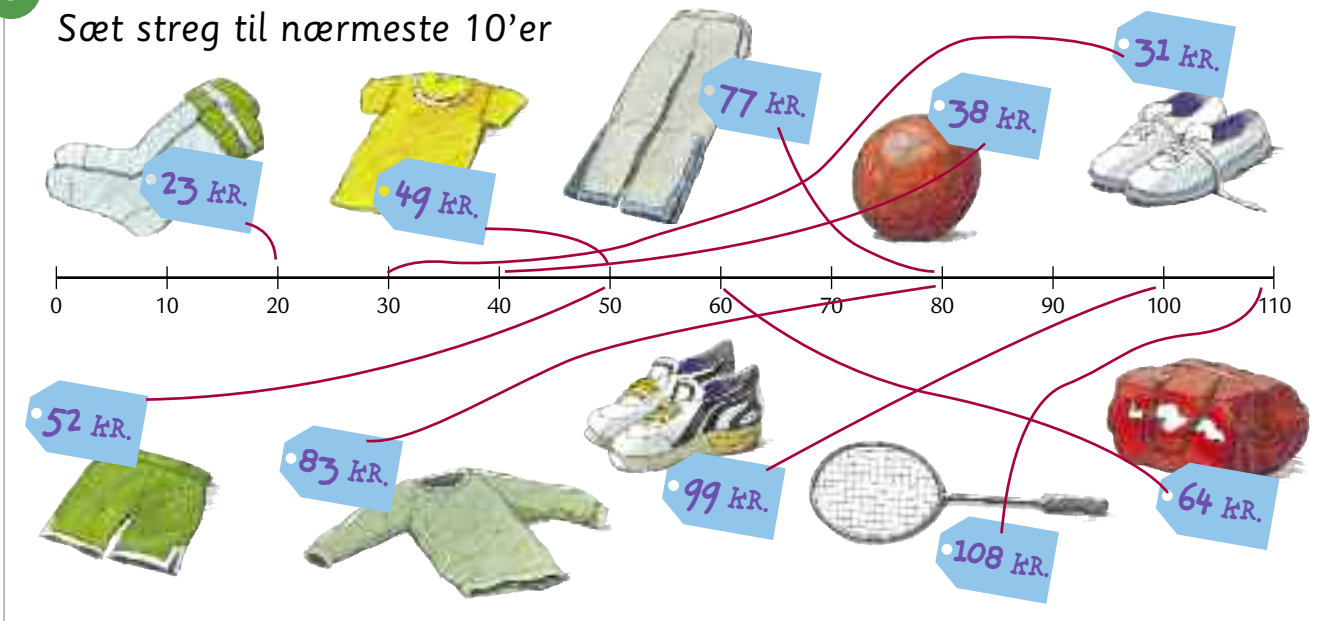

7

Hvad koster tingene?

AFRUND	REGNING
20 kr.	<u>23</u> KR.
<u>40</u> kr.	<u>38</u> KR.
<u>30</u> kr.	<u>31</u> KR.
I alt cirka <u>90</u> kr.	I ALT <u>92</u> KR.

AFRUND	REGNING
<u>60</u> kr.	<u>64</u> KR.
<u>100</u> kr.	<u>99</u> KR.
<u>20</u> kr.	<u>23</u> KR.
I alt cirka <u>180</u> kr.	I ALT <u>186</u> KR.

AFRUND	REGNING
<u>80</u> kr.	<u>77</u> KR.
<u>50</u> kr.	<u>49</u> KR.
<u>80</u> kr.	<u>83</u> KR.
I alt cirka <u>210</u> kr.	I ALT <u>209</u> KR.

AFRUND	REGNING
<u>110</u> kr.	<u>108</u> KR.
<u>50</u> kr.	<u>52</u> KR.
<u>80</u> kr.	<u>77</u> KR.
I alt cirka <u>240</u> kr.	I ALT <u>237</u> KR.



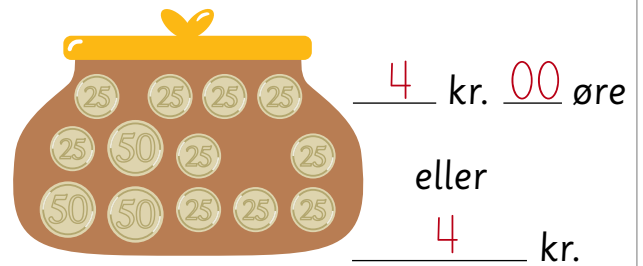
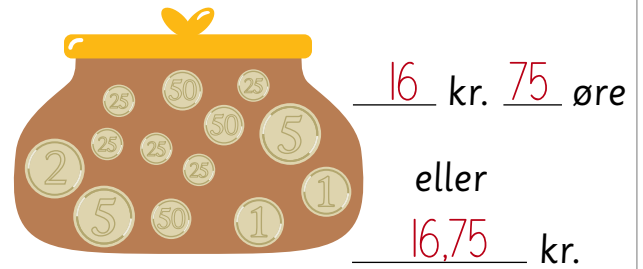

8







Hvor mange penge?







9

Varene bliver dyrere. Skriv den nye pris

Varer + 	Ny pris
	<u>52,25</u> kr.
	<u>108,25</u> kr.
	<u>64,25</u> kr.

Varer +   	Ny pris
	<u>111</u> kr.
	<u>52</u> kr.
	<u>86</u> kr.

Varer +   	Ny pris
	<u>33,50</u> kr.
	<u>79,50</u> kr.
	<u>25,50</u> kr.

Varer +   	Ny pris
	<u>4,75</u> kr.
	<u>102,75</u> kr.
	<u>80,75</u> kr.

10

Vis hvad klokken er



kl. 13.00

kl. 1.00



kl. 19.00

kl. 7.00

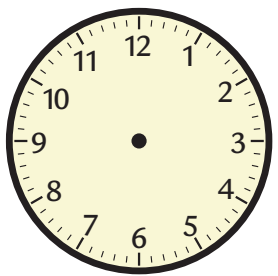

kl. 22.00

kl. 10.00



kl. 16.00

kl. 4.00

1 TIME = 60 MINUTER
HALV TIME = 30 MINUTER

+60 minutter Hel
+45 minutter Kvart i
+30 minutter Halv
+15 minutter Kvart over

11

Skriv hvad klokken er

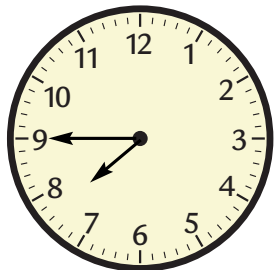

kl. 7.45

kvart i 8

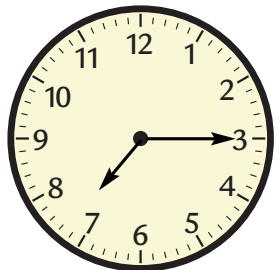

kl. 7.15

kvart over 7

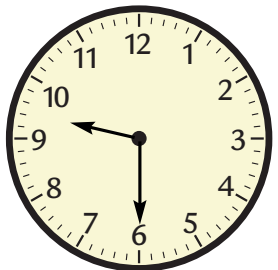

kl. 9.30

halv 10

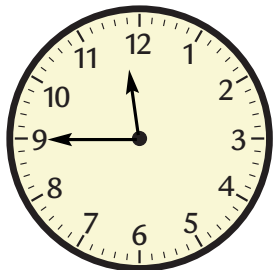

kl. 11.45

kvart i 12

12

Hvor mange minutter er der gået?

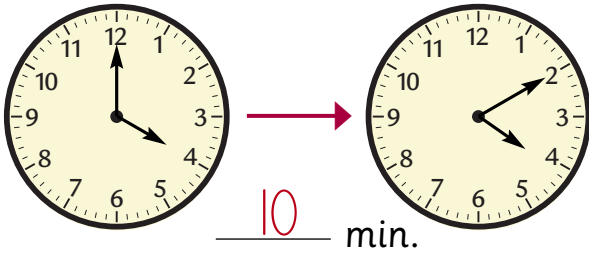
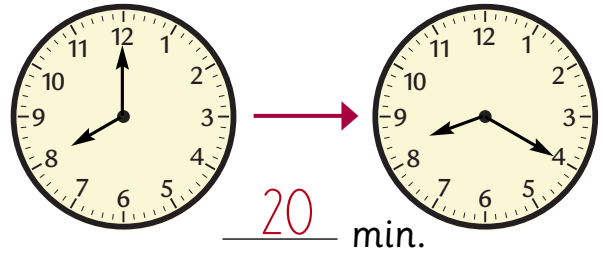
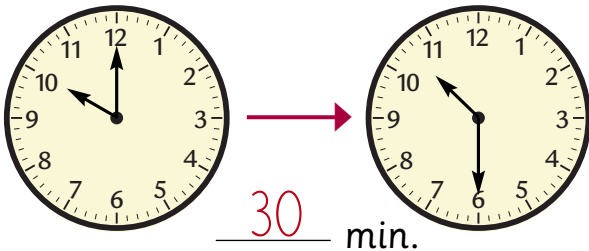
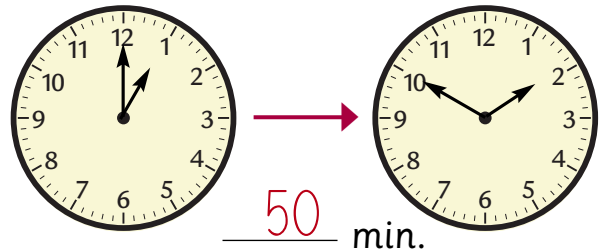
Kl. 4.00Kl. 4.10Kl. 8.00Kl. 8.20Kl. 10.00Kl. 10.30Kl. 1.00Kl. 1.50

13

Sæt visere på urene

10

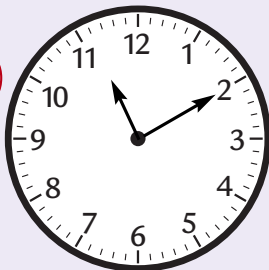

11:10

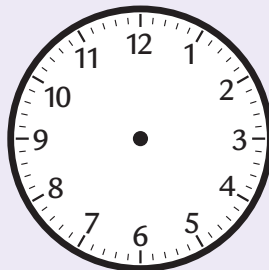

15:32

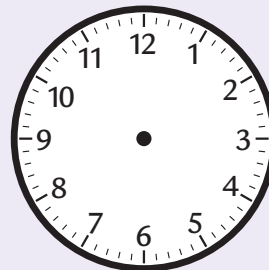

8:20

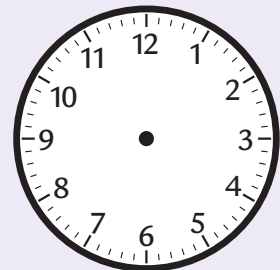

22:45

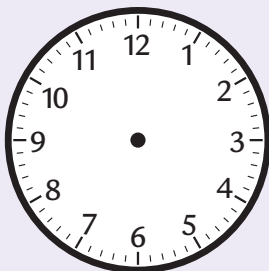

4:02

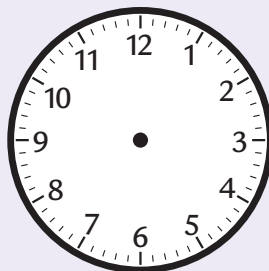
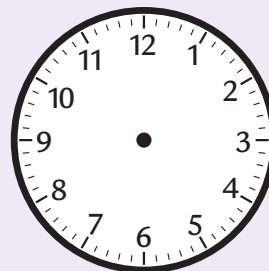
kvart i 9

1:53

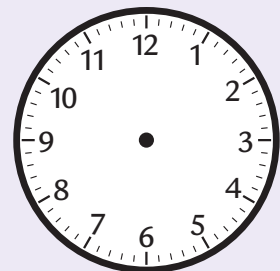
halv 12

12. Skriv klokkeslæt og det antal minutter, der er gået.

13. Sæt visere på urene.

14

5 minutter før og 10 minutter efter

5 min. før	nu	10 min. efter	5 min. før	nu	10 min. efter
11.15	11.20	11.30	9.50	9.55	10.05
18.30	18.35	18.45	17.00	17.05	17.15
4.25	4.30	4.40	2.55	3.00	3.10
22.45	22.50	23.00	6.15	6.20	6.30

15

Hvor lang tid?

KØREPLAN FOR TALBYBUSSEN		
Skole	8.00	} 10 min.
Torv	8.10	
Købmand	8.15	} 5 min.
Gågade	8.17	
Station	8.25	} 2 min.
Posthus	8.33	
Bager	8.41	} 8 min.
Læge	8.49	
Fabrik	9.00	} 8 min.
Svømmehal	9.12	
Park	9.24	} 11 min.
Tandlæge	9.38	
Legeplads	9.50	} 12 min.
Pizzeria	9.58	
Skole	10.17	} 14 min.
		} 12 min.
		} 8 min.
		} 19 min.

Antal minutter

Fra skole til gågade 17 min.

Fra bager til fabrik 19 min.

Fra svømmehal til legeplads 38 min.

Fra læge til park 35 min.

Fra pizzeria til skole 19 min.

Fra torv til pizzeria 108 min.

Hvad hedder figurerne?



1 Find figurer med samme form. Farv dem



b = blå r = rød gu = gul gr = grøn

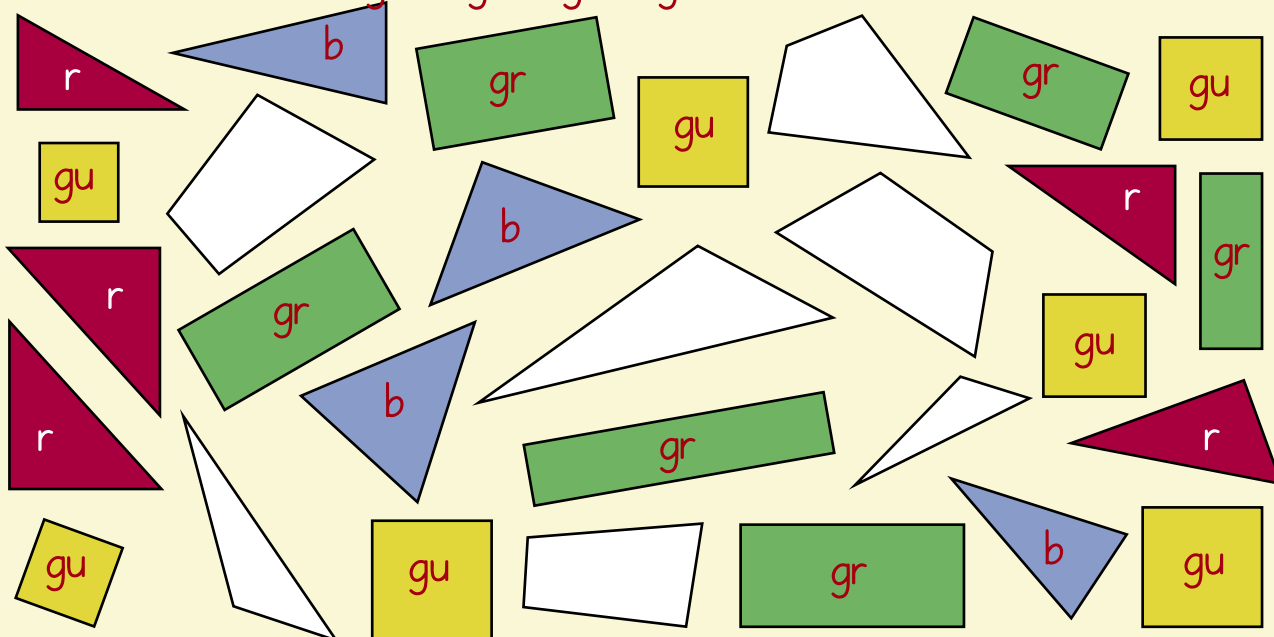

2

Tegn skilte på prikpapier

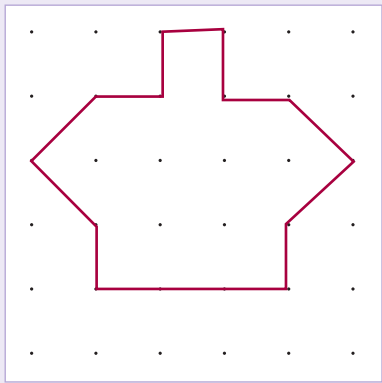
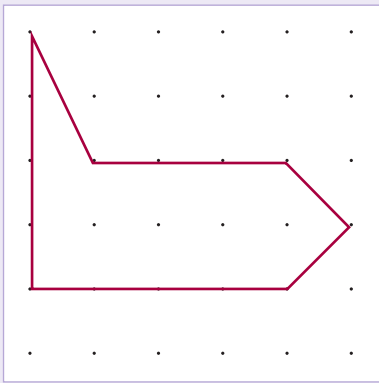
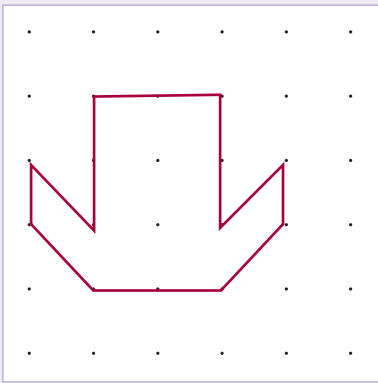
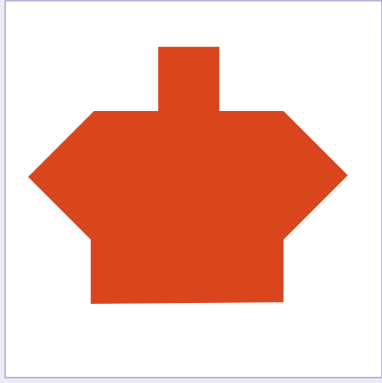
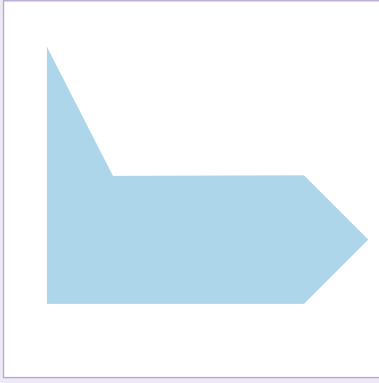
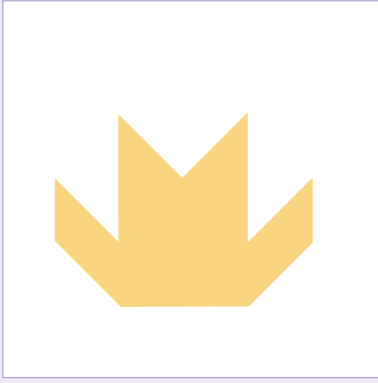

3

Tegn to figurer til

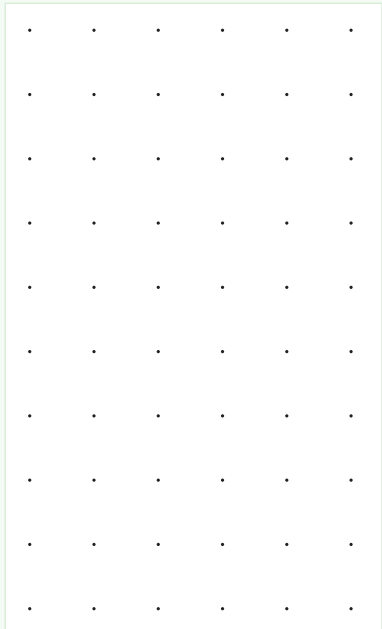
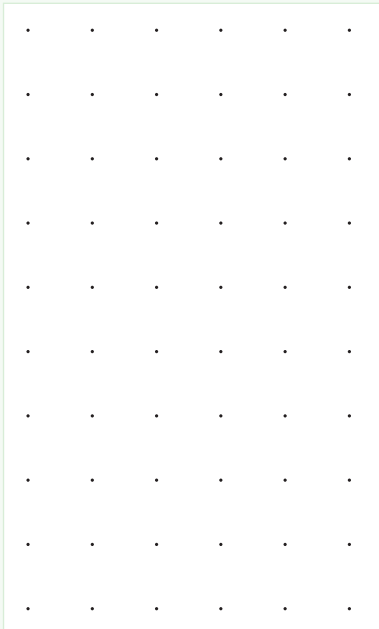
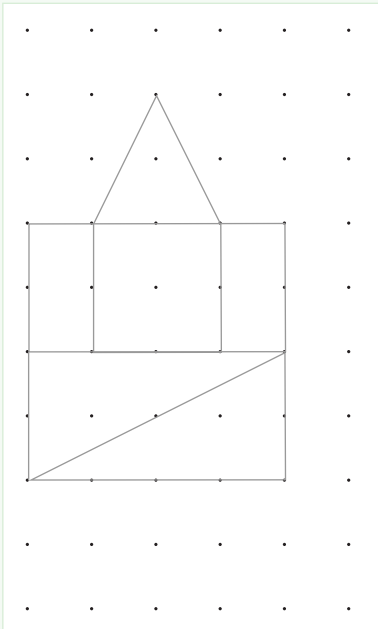

1	2	1	2

- 2. Tegn skiltene på prikpapier.
- 3. Tegn selv to figurer og udfyld skemaerne.

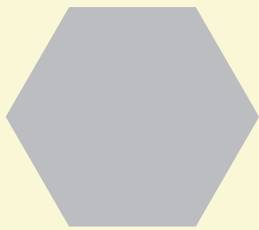

30 kr.



15 kr.



10 kr.



5 kr.

4

Hvad koster figurerne?

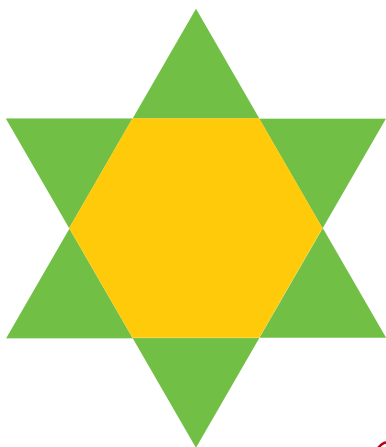

60 kr.

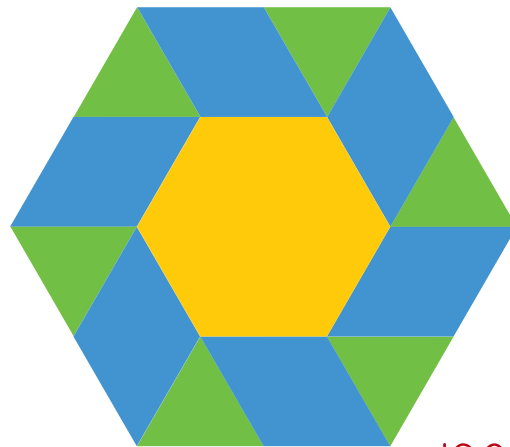

120 kr.

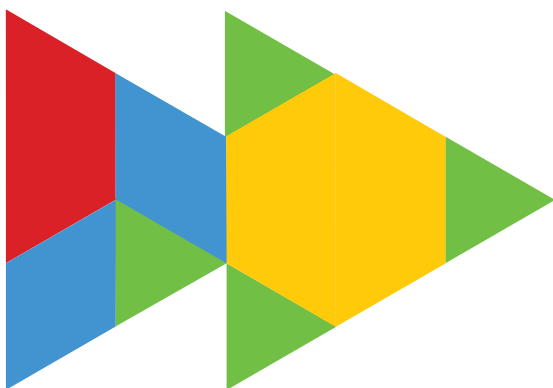

85 kr.

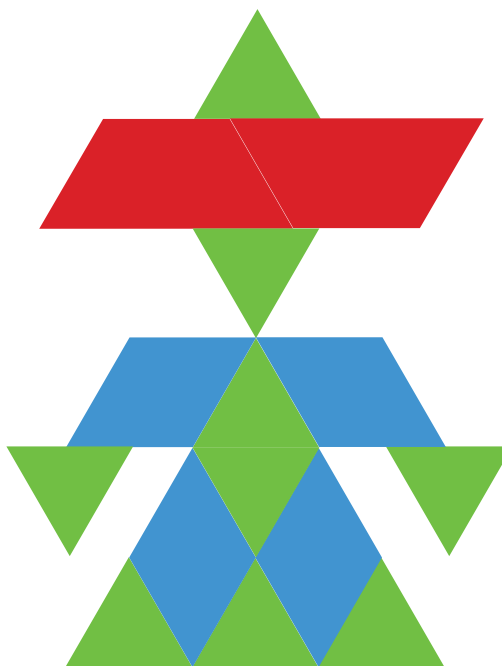

115 kr.

5

Byg og farv flere figurer for 60 kr. *Flere løsninger*



6

Byg flere figurer for 120 kr. *Flere løsninger*

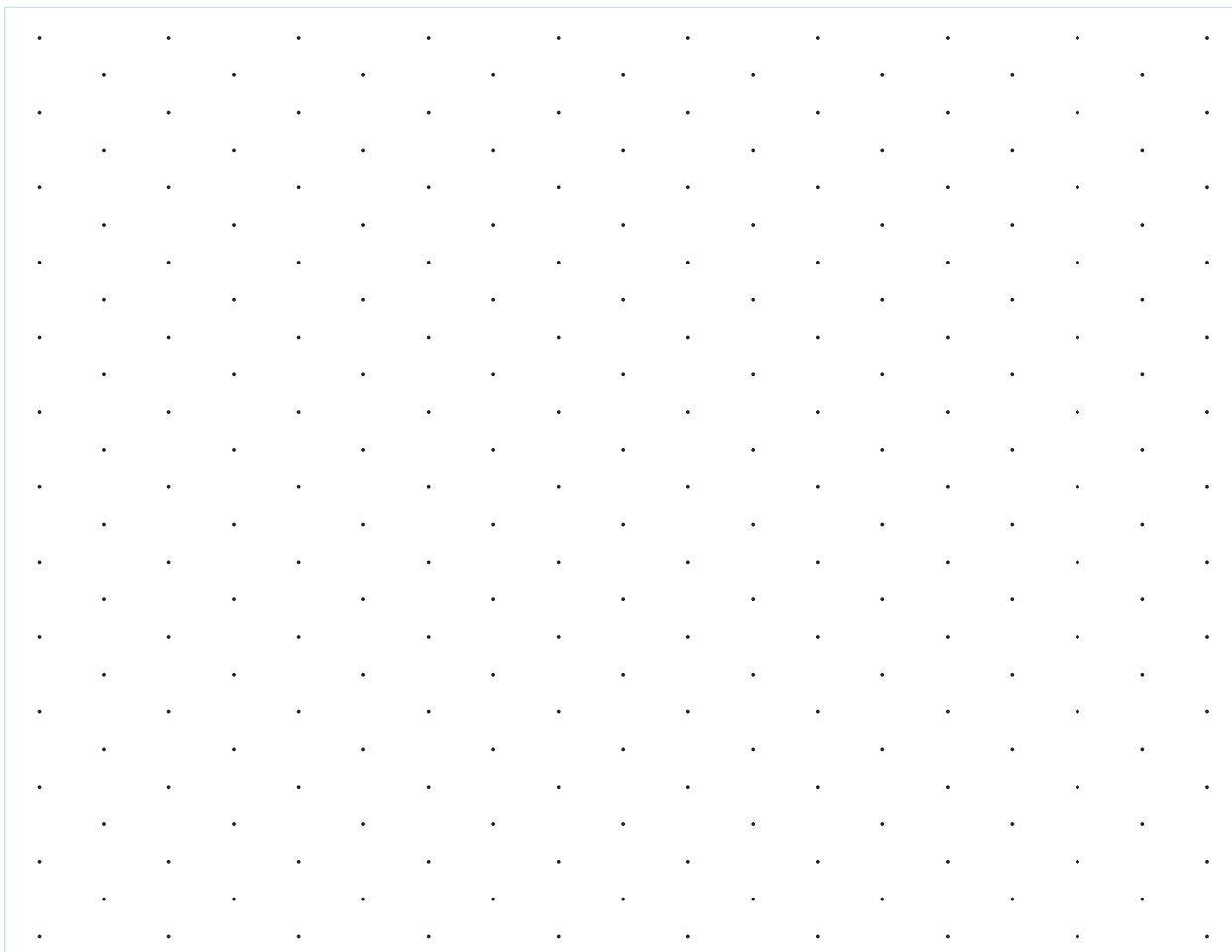

7

Hvor stor er omkredsen?

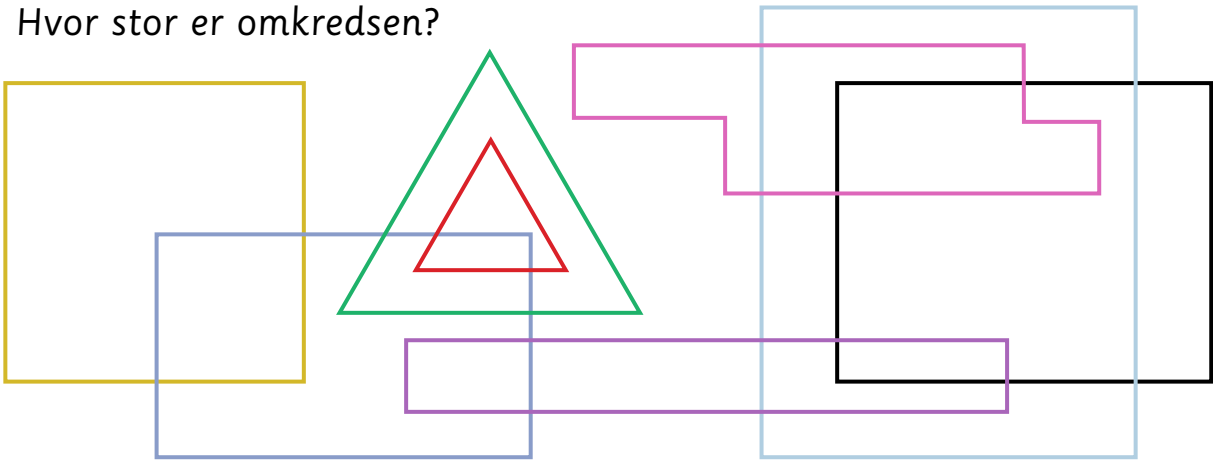

● $4 + 4 + 4 + 4 = 16$ cm

● $1 + 2 + 1 + 5 + 1 + 1 + 1 + 6 = 18$ cm

● $5 + 3 + 5 + 3 = 16$ cm

● $1 + 8 + 1 + 8 = 18$ cm

● $4 + 4 + 4 = 12$ cm

● $5 + 6 + 5 + 6 = 22$ cm

● $2 + 2 + 2 = 6$ cm

● $5 + 4 + 5 + 4 = 18$ cm

8

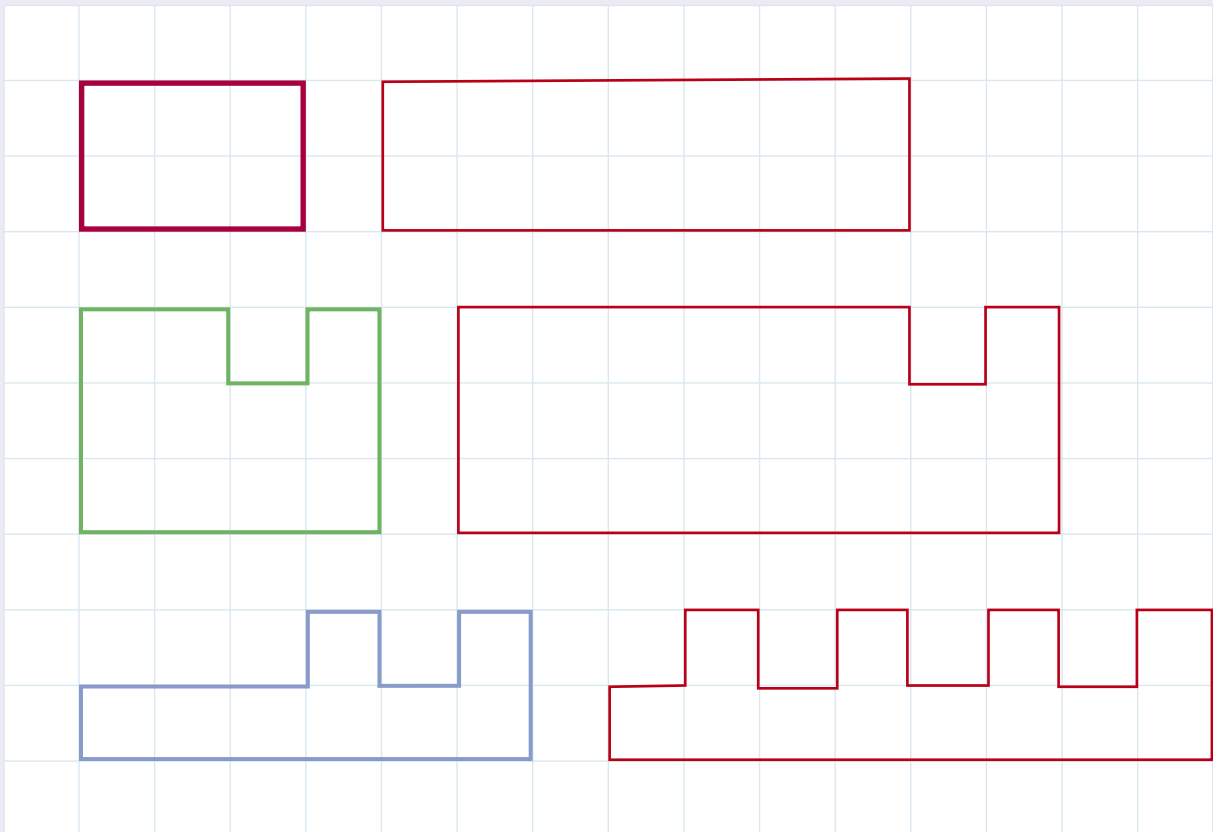
Tegn figurer så omkredsen bliver 8 cm længere **Eksempelvis som her:**

9

Gør siderne dobbelt så store

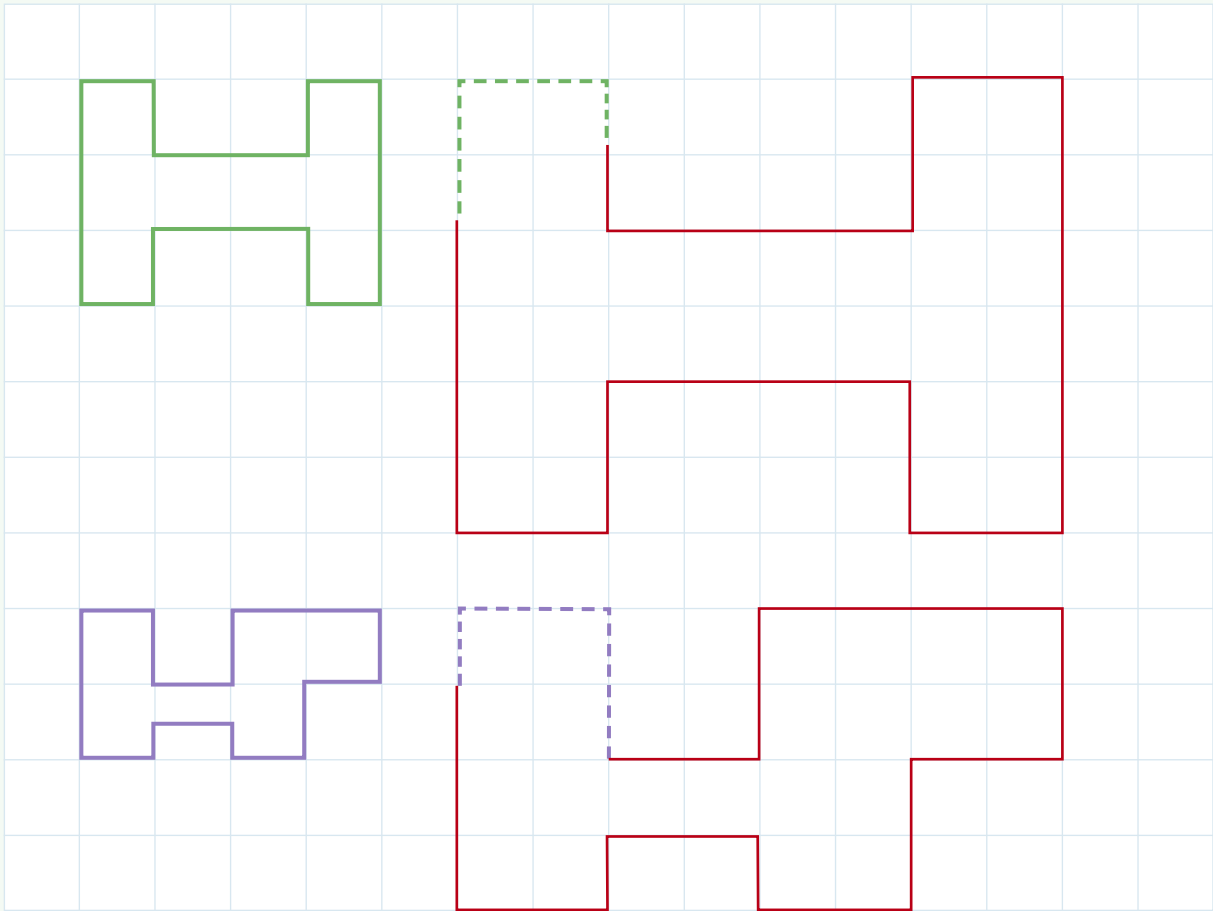

10

Gør siderne halvt så store

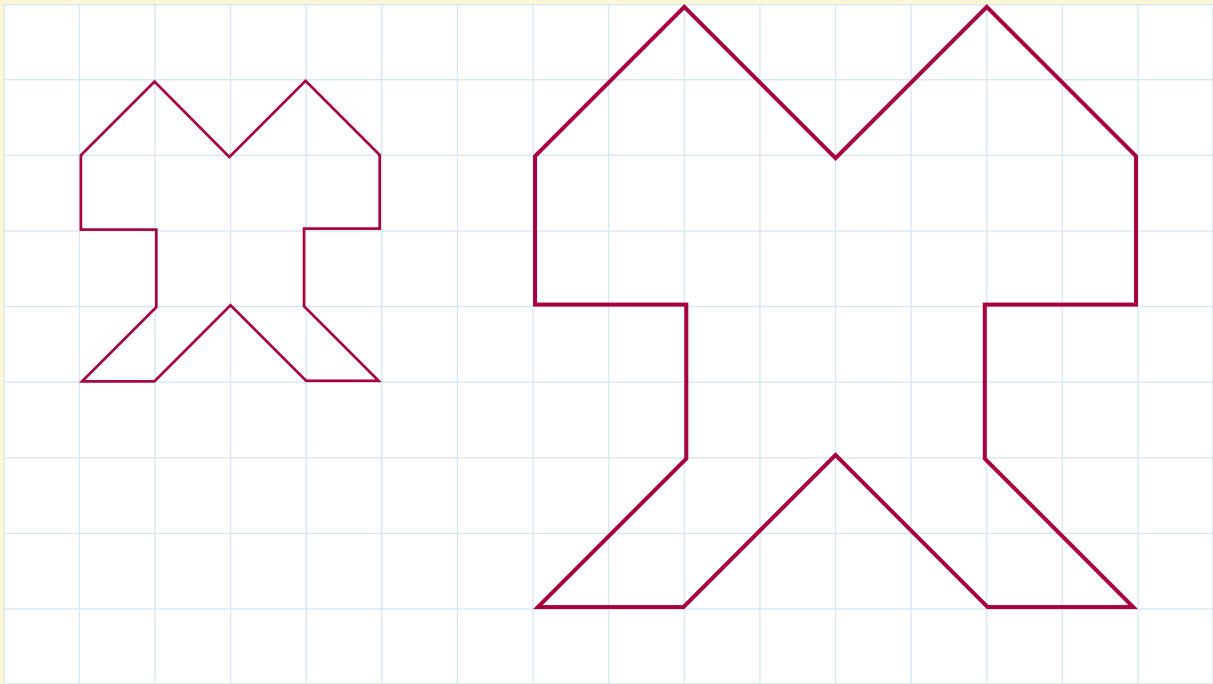

9. Siderne gøres dobbelt så store, og de nye figurer tegnes.
10. Siderne halveres, og den nye figur tegnes.

Gør siderne dobbelt så store

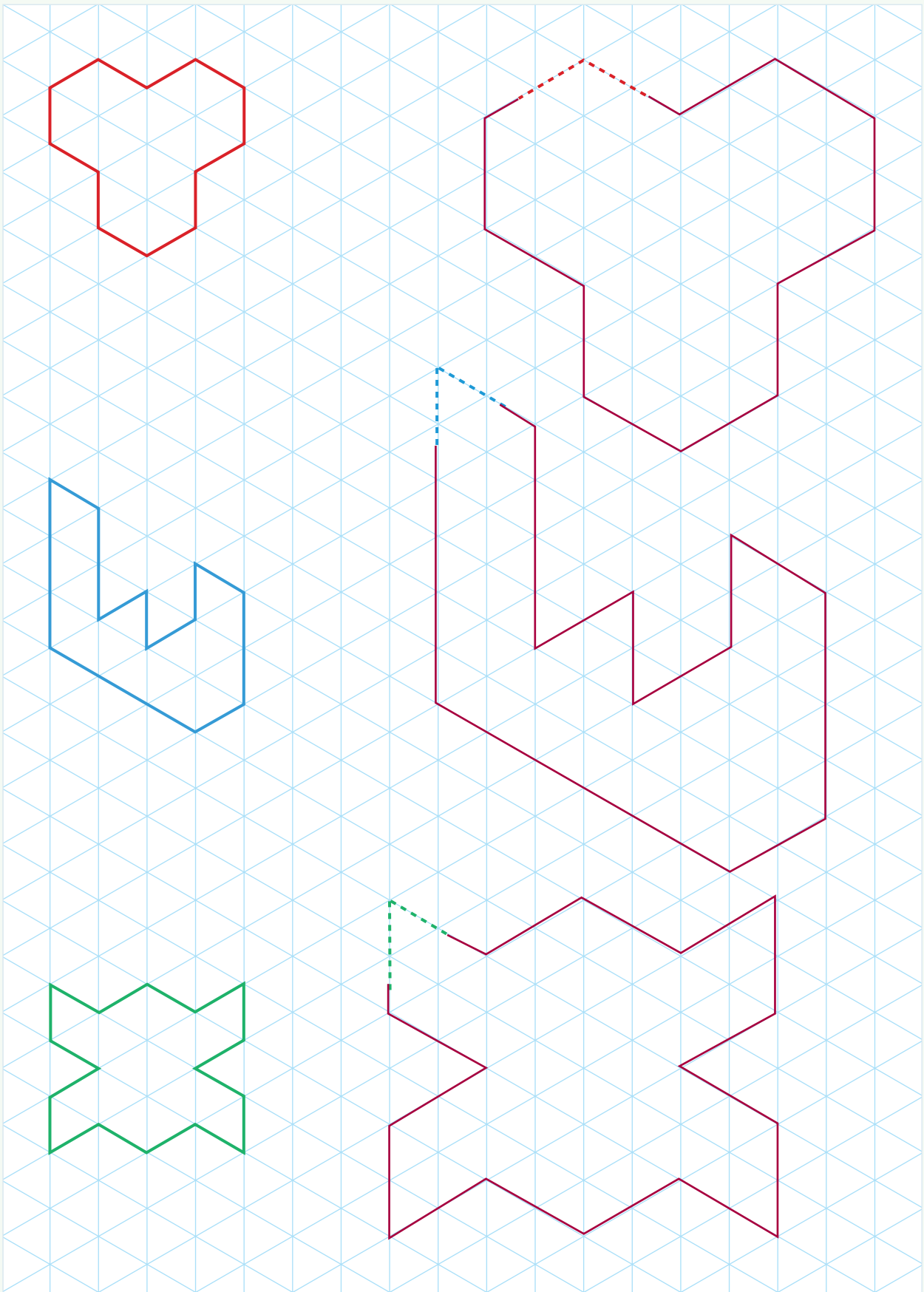

Tegn figuren på nye net

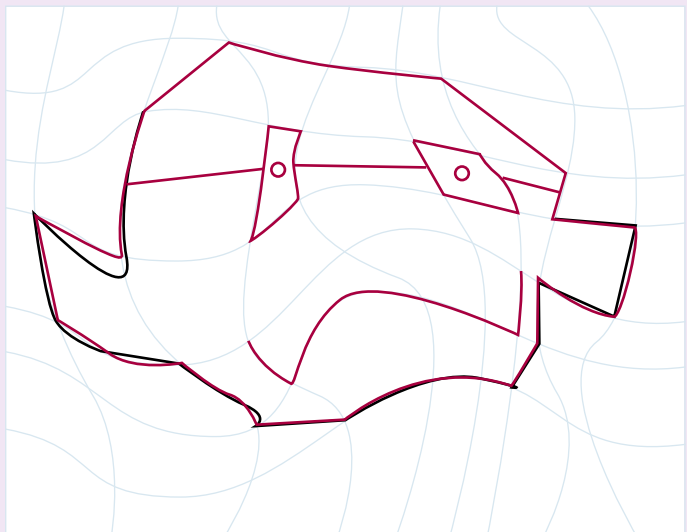
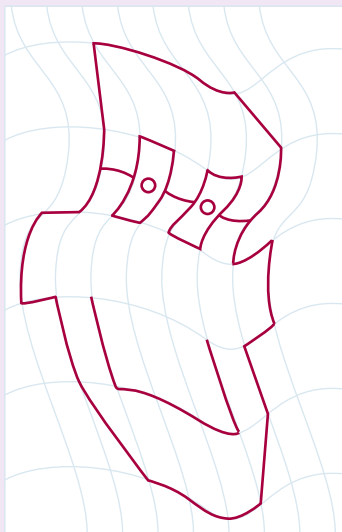
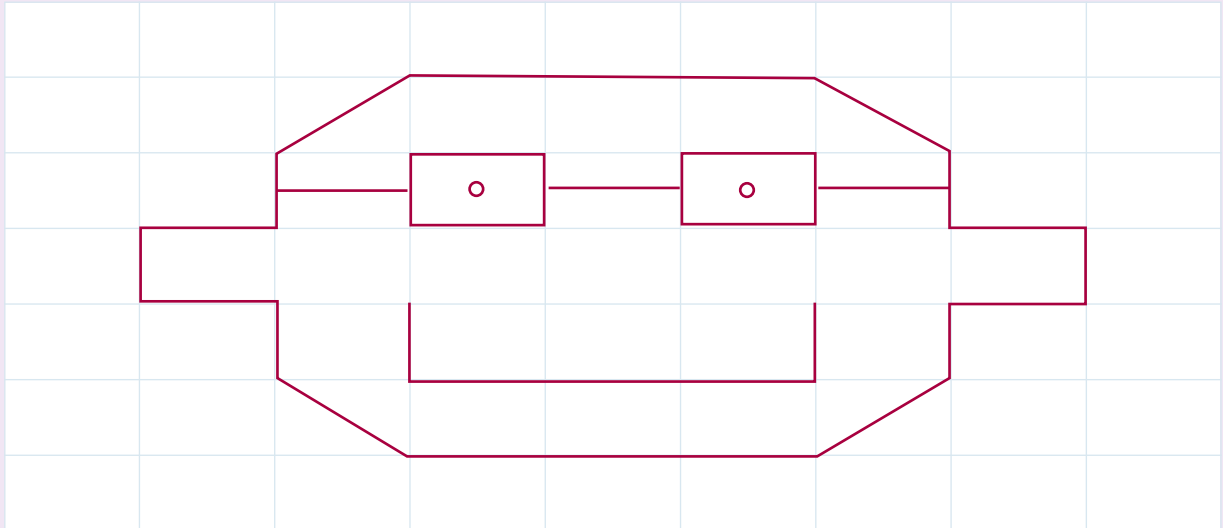
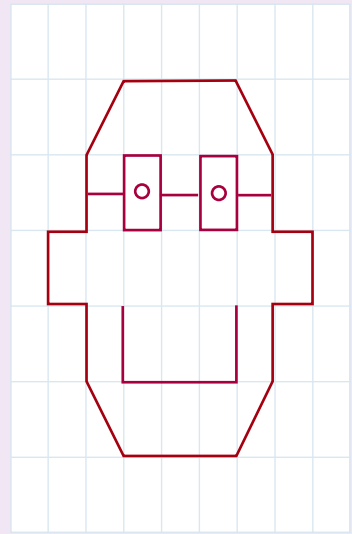
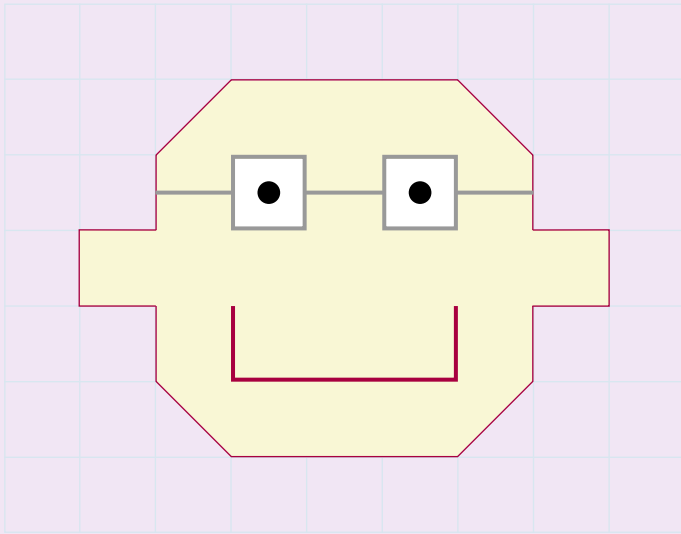

Hvor er skatten?

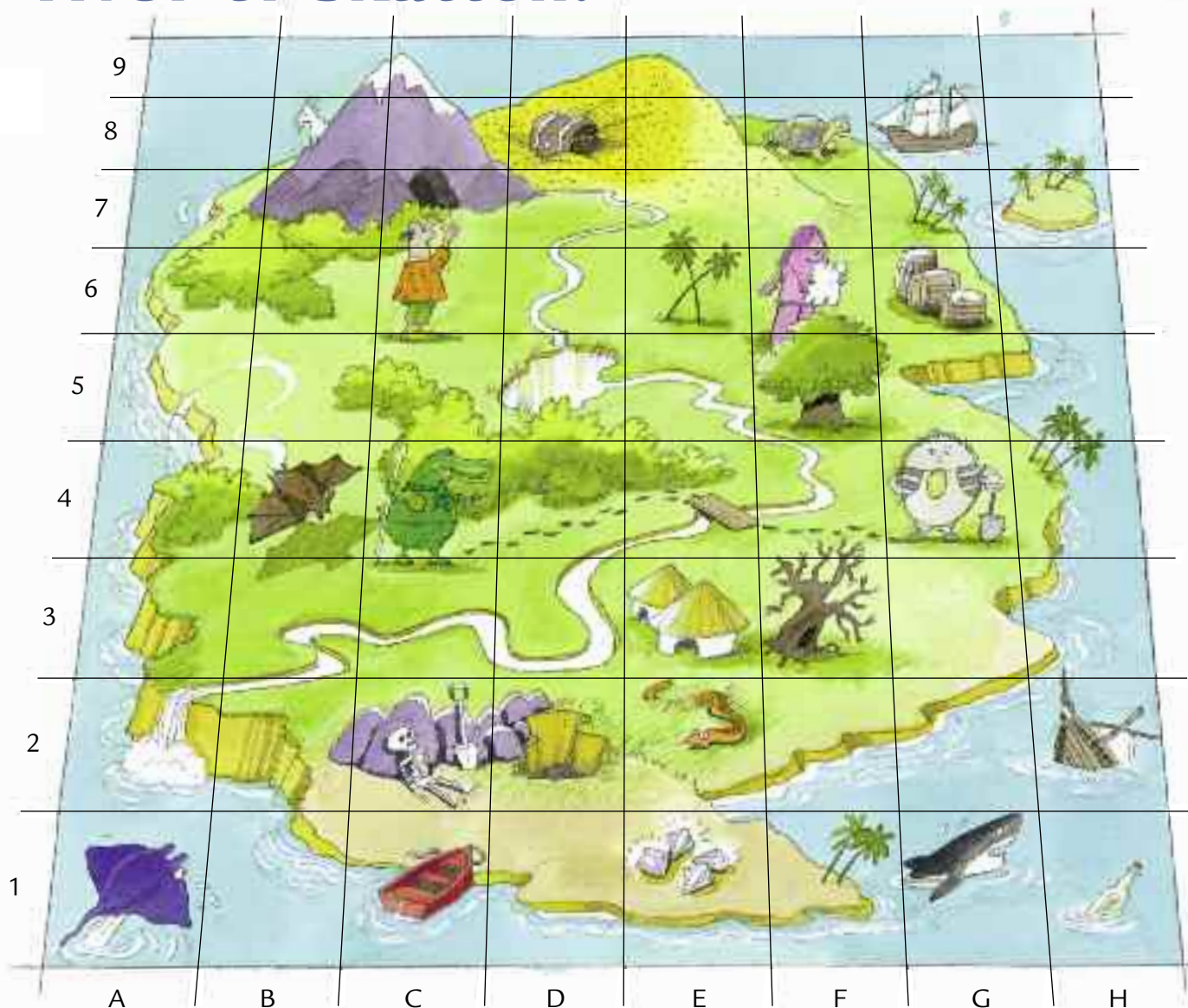

1

Hvor er ...?



D8



F8



H7



G6



B4



D5



E1



C2



E3



C7



G1



E2



F3



H2















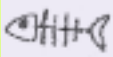

A2















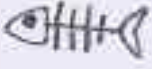



H1

2

Tegn på øen

10										
9										
8										
7										
6										
5										
4										
3										
2										
1										
	A	B	C	D	E	F	G	H	I	J

	<u> </u>		<u> </u>		<u> </u>		<u> </u>
	<u>C9</u>		<u>D3</u>		<u>G1</u>		<u>H7</u>
	<u> </u>		<u> </u>		<u> </u>		<u> </u>
	<u>H8</u>		<u>I6</u>		<u>G9</u>		<u>G3</u>
	<u> </u>		<u> </u>		<u> </u>		<u> </u>
	<u>E5</u>		<u>B8</u>		<u>E6</u>		<u>B10</u>
	<u> </u>		<u> </u>		<u> </u>		<u> </u>
	<u>E8</u>		<u>F4</u>		<u>D2</u>		<u>I5</u>

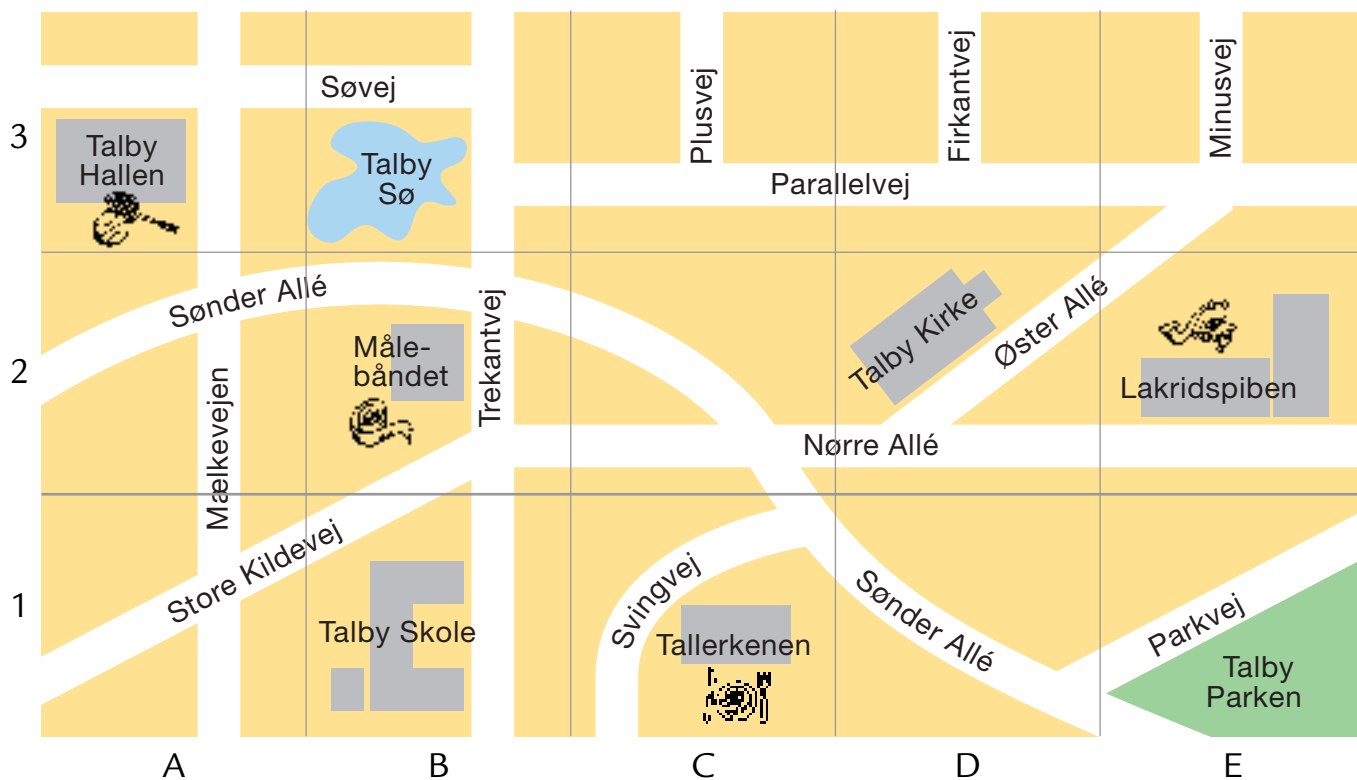

3

Hvor ligger ...?

Talbyhallen	A3	Tallerkenen	C1	Lakridspiben	E2
Talby Skole	B1	Svingvej	C1	Målebåndet	B2
Talby Sø	B3	Talby Kirke	D2	Talby Parken	E1

4

Hvilke veje ligger i ...?

A2	Sønner Alle, Mælkevejen
E3	Minusvej, Parallelvej, Øster Alle
B2	Trekantvej, Sønner Alle, Store Kildevej, Nørre Alle

5

Farv mønstret

gr = grøn

gu = gul

r = rød

b = blå

10	gu	gu	gr	gu	gu	A1	A2	A9	B1	B5	B6	C5	C9
9	gr	r	gr	gu	r	C10	D1	D2	D9	E1	E5	E6	
8	b	r	r	b	r	A6	A10	B2	B3	B10	C2	C6	C7
7	b	b	gu	b	b	D6	D10	E2	E3	E10			
6	gu	gr	gu	gu	gr	A4	A5	B4	B8	B9	C1	C8	D4
5	r	gr	gr	r	gr	D5	E4	E8	E9				
4	r	r	b	r	r	A3	A7	A8	B7	C3	C4	D3	D7
3	b	gu	b	b	gu	D8	E7						
2	gr	gu	gu	gr	gu								
1	gr	gr	r	gr	gr								
	A	B	C	D	E								

6

Farv dit eget mønster

Eleverne vælger selv et mønster

10													
9													
8													
7													
6													
5													
4													
3													
2													
1													
	A	B	C	D	E								

5. Farv felterne efter anvisningen i felterne til højre.

6. Farv et mønster og skriv anvisningen i felterne.

7

Tegn kuben

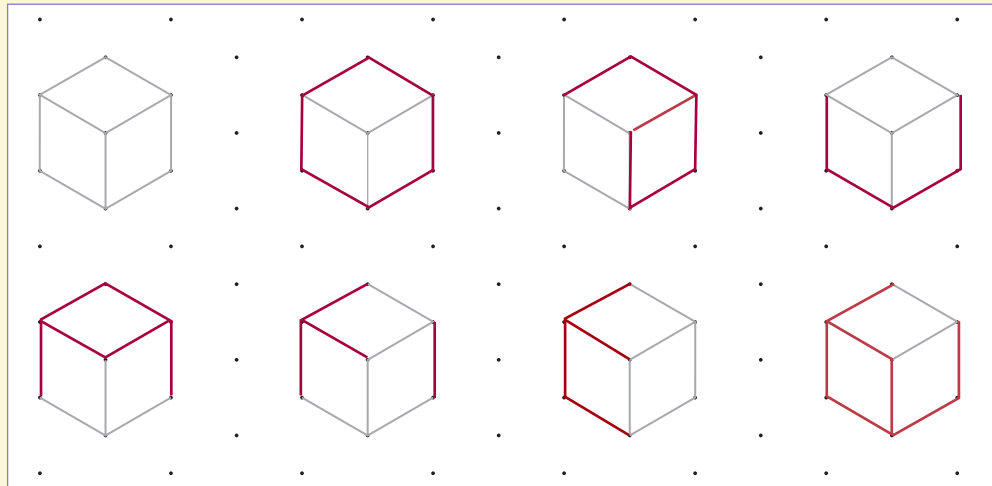
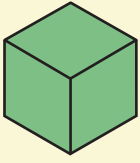

8

Tegn to kuber

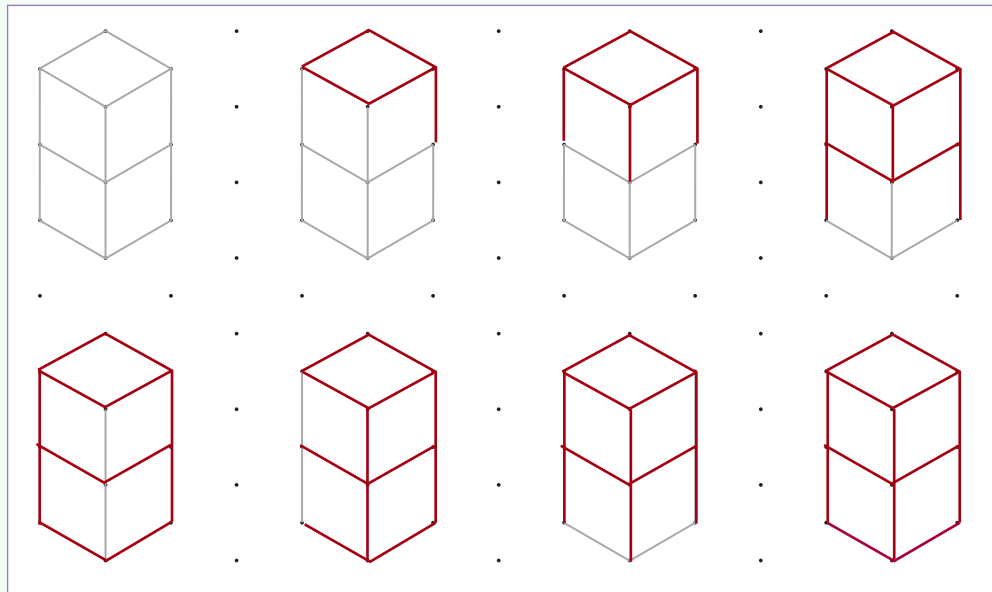
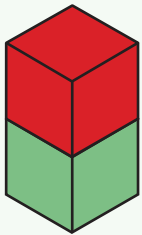

9

Tegn figuren færdig

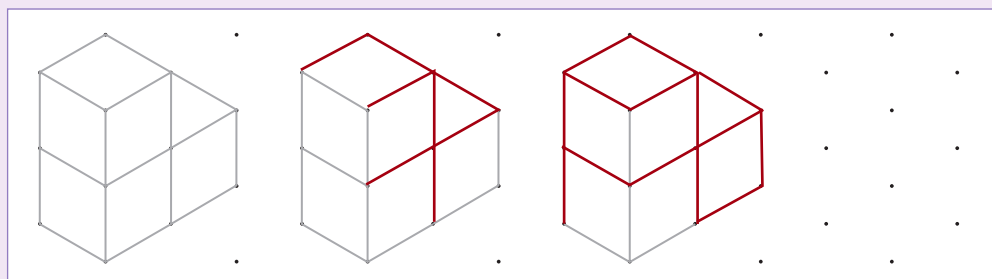
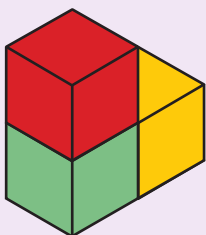

10

Byg og tegn

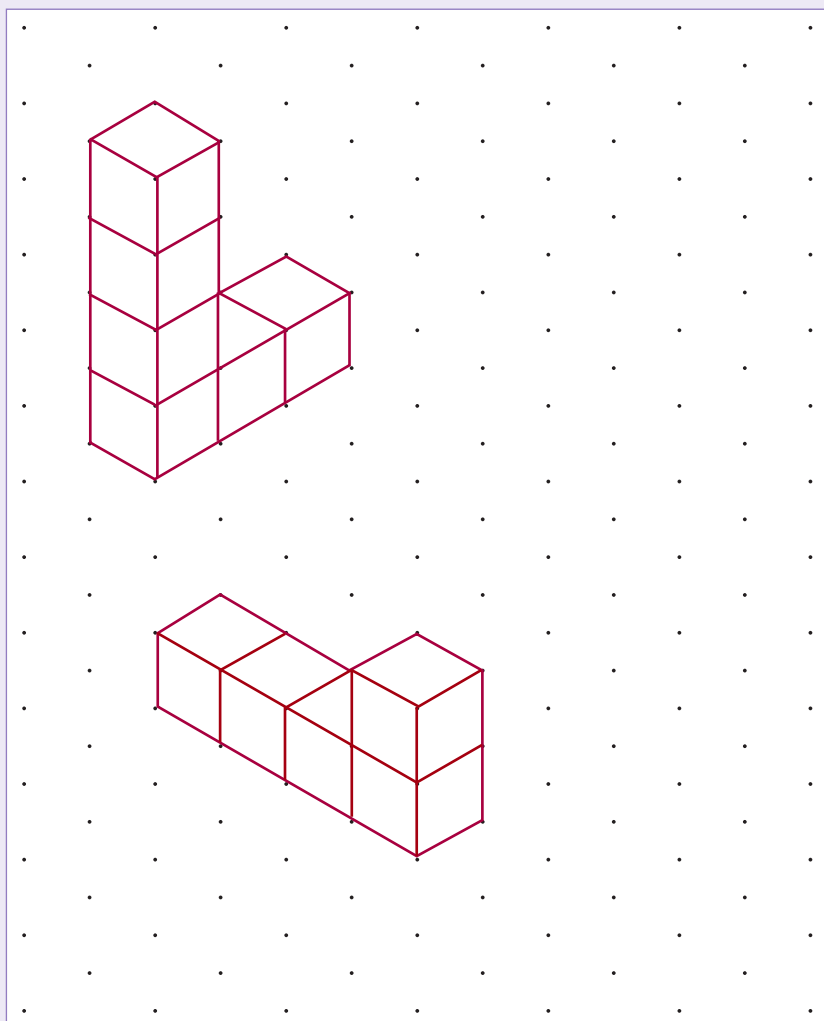
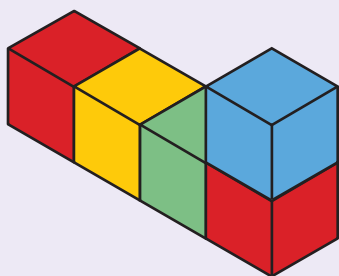
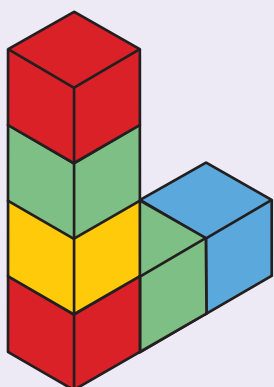

11

Farv figuren fra forskellige sider r = rød b = blå gu = gul gr = grøn

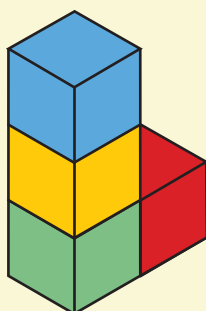

10. Byg de to figurer. Tegn og farv dem.
 11. Farv figuren set fra de forskellige sider.

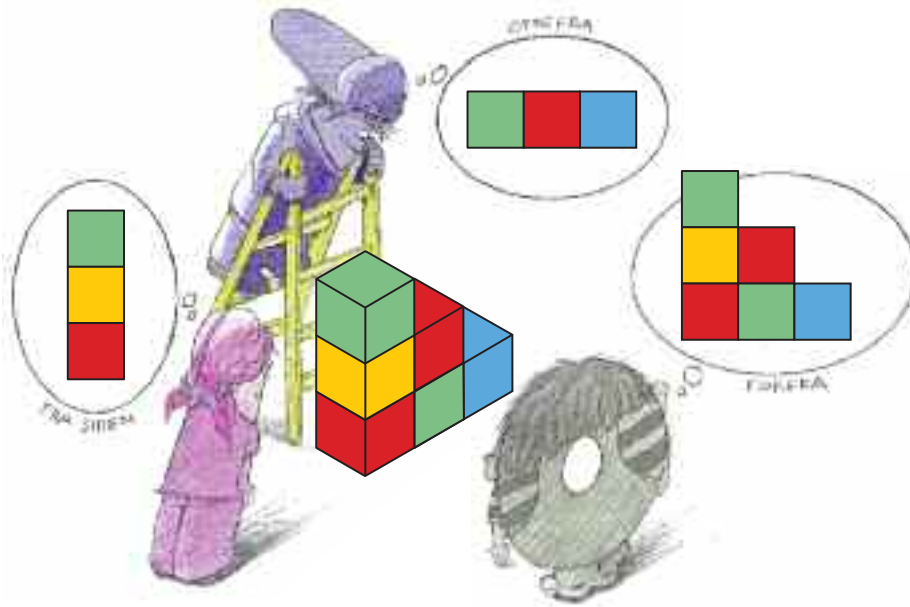

12

Byg og tegn

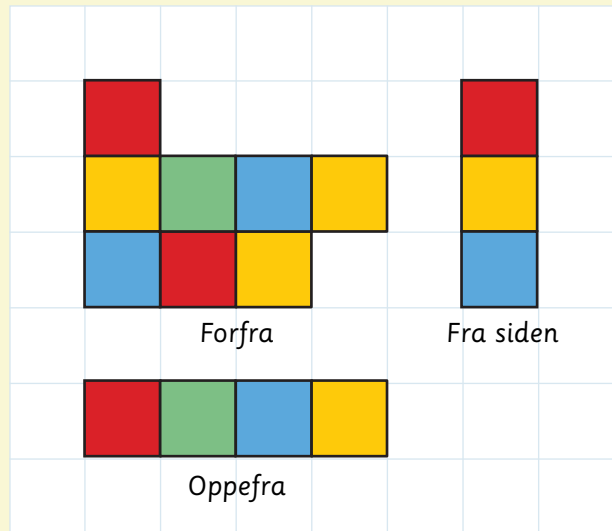
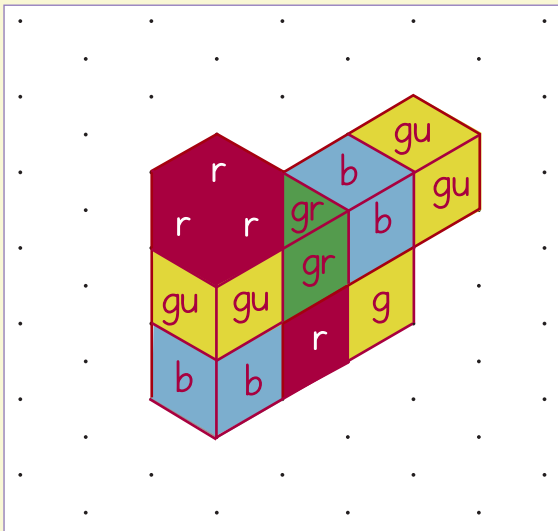

r = rød b = blå gu = gul gr = grøn

13

Byg selv og tegn Eleverne finder selv på en figur.

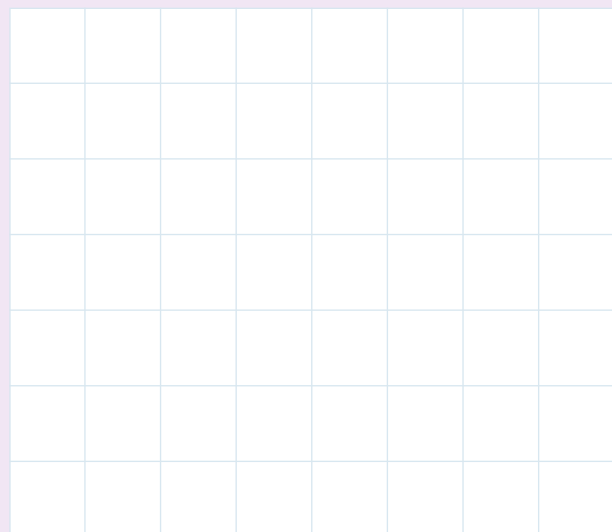
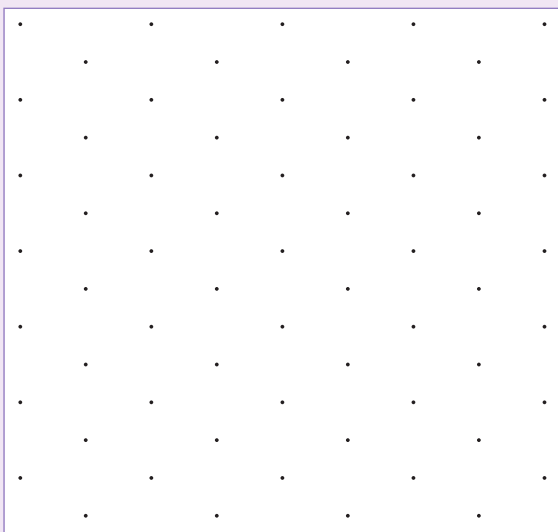

1 Tegn figurer Eleverne finder selv på, hvordan antallet af de forskellige figurer skal sammensættes.

•	•	•	•	•	•	•	•
•	•	•	•	•	•	•	•
•	•	•	•	•	•	•	•
•	•	•	•	•	•	•	•
•	•	•	•	•	•	•	•
•	•	•	•	•	•	•	•
•	•	•	•	•	•	•	•
•	•	•	•	•	•	•	•

•	•	•	•	•	•	•	•
•	•	•	•	•	•	•	•
•	•	•	•	•	•	•	•
•	•	•	•	•	•	•	•
•	•	•	•	•	•	•	•
•	•	•	•	•	•	•	•
•	•	•	•	•	•	•	•
•	•	•	•	•	•	•	•

3	4	3	2

2	3	1	1

2 Tegn to figurer med omkredsen 12 cm

3 Tegn

r = rød
 b = blå
 gu = gul
 gr = grøn

1. Tegn figurer, så det passer med antal former.
2. Tegn mindst én figur med omkredsen 12 cm.
3. Tegn figuren og farv den. Begynd evt. med at bygge den.

Får vi det samme?



1

Hvordan regner Tænksomme To og Opfindsomme Otte?

$$12 + 17 = \underline{29}$$

$$17 + 12 = \underline{29}$$

2

Plus

$$9 + 15 = \underline{24}$$

$$15 + 9 = \underline{24}$$

$$13 + 26 = \underline{39}$$

$$26 + 13 = \underline{39}$$

$$22 + 28 = \underline{50}$$

$$28 + 22 = \underline{50}$$

$$27 + 15 = \underline{42}$$

$$15 + 27 = \underline{42}$$

$$21 + 30 = \underline{51}$$

$$30 + 21 = \underline{51}$$

3

Plus

$$21 + 27 = \underline{48}$$

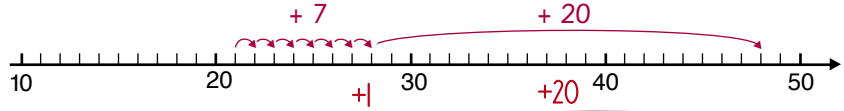

$$27 + 21 = \underline{48}$$

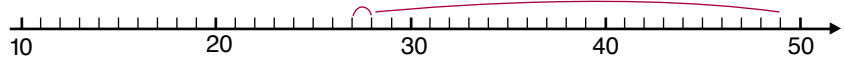

$$13 + 33 = \underline{46}$$

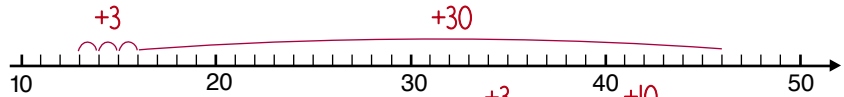

$$33 + 13 = \underline{46}$$

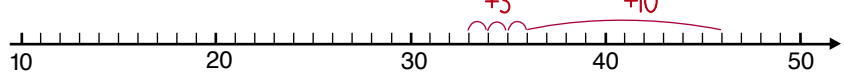

$$17 + 40 = \underline{57}$$

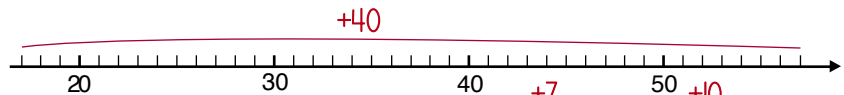

$$40 + 17 = \underline{57}$$

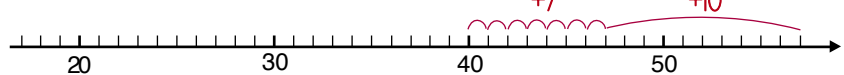

$$26 + 34 = \underline{60}$$



$$34 + 26 = \underline{60}$$



$$33 + 38 = \underline{71}$$

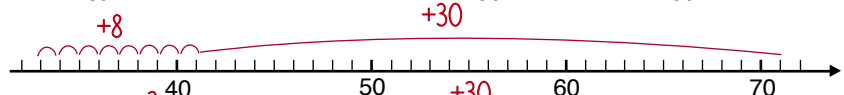

$$38 + 33 = \underline{71}$$



4

Plus

$$17 + \underline{24} = 41$$

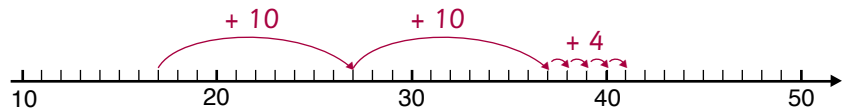

$$\underline{18} + 28 = 46$$

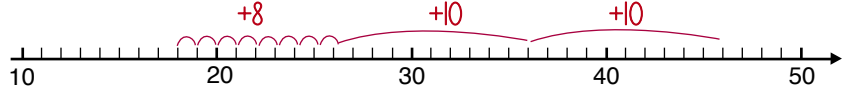

$$26 + \underline{26} = 52$$

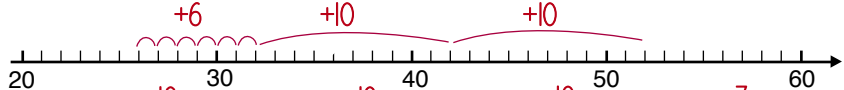

$$\underline{25} + 37 = 62$$

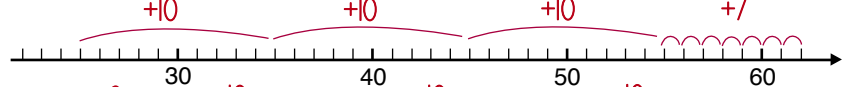

$$23 + \underline{33} = 56$$

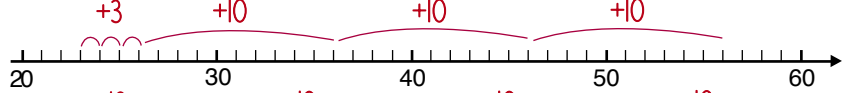

$$\underline{36} + 40 = 76$$

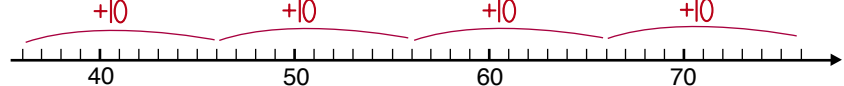

5

Skriv tal på tallinjen og plus

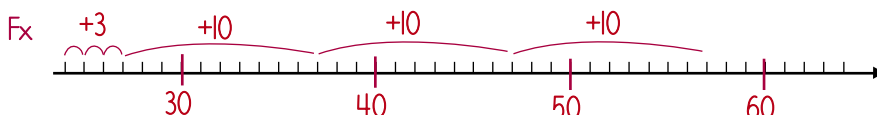

$$24 + 33 = \underline{57}$$

3.-4. Regn plusstykkerne og vis dem på tallinjen.
5. Skriv tal på tallinjen, så tallinjen kan bruges til at regne plusstykket, og find resultatet.

6

Plus i taltavlen

$$14 + 24 = \underline{38}$$

$$23 + 12 = \underline{35}$$

$$27 + 20 = \underline{47}$$

$$21 + 23 = \underline{44}$$

$$32 + \underline{27} = 59$$

$$36 + \underline{21} = 57$$

30	31	32	33	34	35	36	37	38	39
20	21	22	23	24	25	26	27	28	29
10	11	12	13	14	15	16	17	18	19

30	31	32	33	34	35	36	37	38	39
20	21	22	23	24	25	26	27	28	29
10	11	12	13	14	15	16	17	18	19

40	41	42	43	44	45	46	47	48	49
30	31	32	33	34	35	36	37	38	39
20	21	22	23	24	25	26	27	28	29

40	41	42	43	44	45	46	47	48	49
30	31	32	33	34	35	36	37	38	39
20	21	22	23	24	25	26	27	28	29

50	51	52	53	54	55	56	57	58	59
40	41	42	43	44	45	46	47	48	49
30	31	32	33	34	35	36	37	38	39

50	51	52	53	54	55	56	57	58	59
40	41	42	43	44	45	46	47	48	49
30	31	32	33	34	35	36	37	38	39

7

Skriv tal i taltavlen
og plus

$$20 + 25 = \underline{45}$$

$$43 + 26 = \underline{69}$$

$$55 + 22 = \underline{77}$$

40	41	42	43	44	45	46	47	48	49
30	31	32	33	34	35	36	37	38	39
20	21	22	23	24	25	26	27	28	29

60	61	62	63	64	65	66	67	68	69
50	51	52	53	54	55	56	57	58	59
40	41	42	43	44	45	46	47	48	49

70	71	72	73	74	75	76	77	78	79
60	61	62	63	64	65	66	67	68	69
50	51	52	53	54	55	56	57	58	59

8

Lidt større og lidt mindre

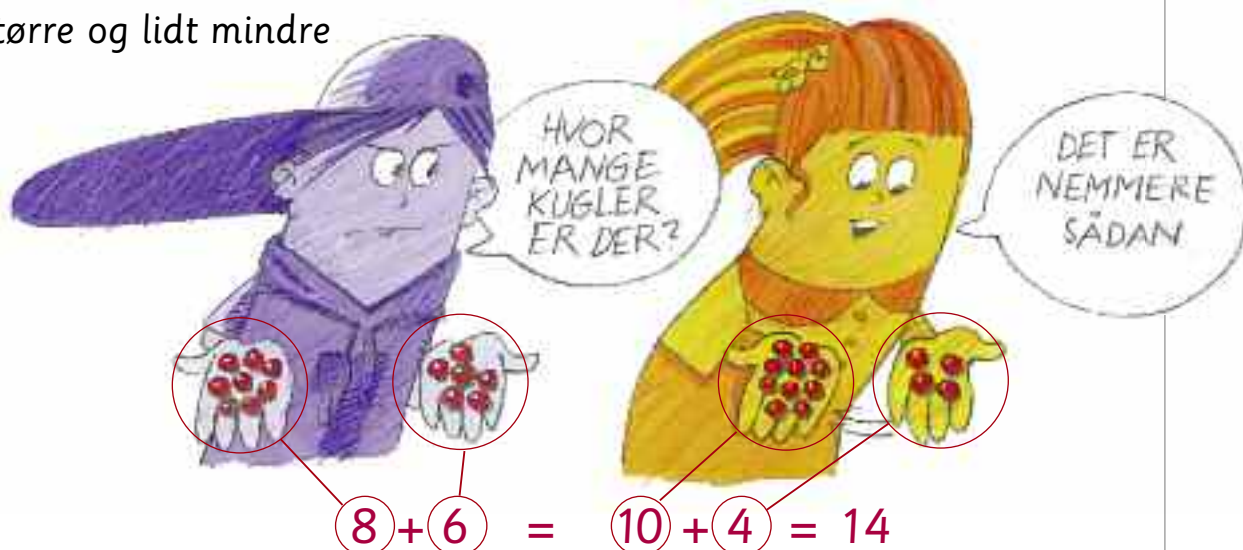

$$9 + 7 = \underline{10} + \underline{6} = \underline{16}$$

$$23 + 5 = \underline{20} + \underline{8} = \underline{28}$$

$$7 + 6 = \underline{10} + \underline{3} = \underline{13}$$

$$24 + 6 = \underline{20} + \underline{10} = \underline{30}$$

$$12 + 6 = \underline{10} + \underline{8} = \underline{18}$$

$$27 + 5 = \underline{30} + \underline{2} = \underline{32}$$

$$19 + 7 = \underline{20} + \underline{6} = \underline{26}$$

$$28 + 8 = \underline{30} + \underline{6} = \underline{36}$$

$$22 + 6 = \underline{20} + \underline{8} = \underline{28}$$

$$8 + 13 = \underline{10} + \underline{11} = \underline{21}$$

$$21 + 8 = \underline{20} + \underline{9} = \underline{29}$$

$$13 + 16 = \underline{10} + \underline{19} = \underline{29}$$

9

Vis hvordan du regner **Eleverne vælger selv regnemethoden.**

17 + 12	13 + 14	21 + 23
29	27	44
16 + 23	20 + 37	32 + 46
39	57	78

8. Brug metoden til at regne plusstykkerne.

9. Regn de seks plusstykker. Vis, hvordan du kom frem til resultatet.

10

Plus

$25 + 34 = 59$

		25
		34
5	9	59

$17 + 21 = 38$

		17
		21
3	8	38

$23 + 26 = 49$

		23
		26
4	9	49

$31 + 27 = 58$

		31
		27
5	8	58

$24 + 11 = 35$

		24
		11
3	5	35

$31 + 18 = 49$

		31
		18
4	9	49

11

Tegn selv plusstykkerne

$12 + 17 = 29$

		12
		17
2	9	29

$26 + 22 = 48$

		26
		22
4	8	48

$30 + 21 = 51$

		30
		21
5	1	51

$\underline{\quad} + \underline{\quad} = 48$

$\underline{\quad} + \underline{\quad} = 57$

$\underline{\quad} + \underline{\quad} = 63$

12

Plus med veksling

$26 + 16 = 42$

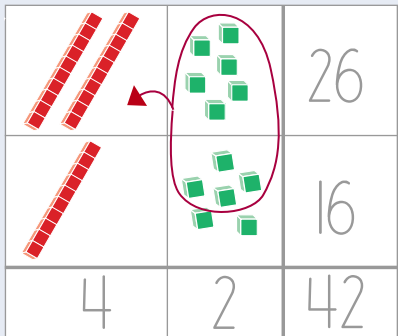

$28 + 17 = 45$

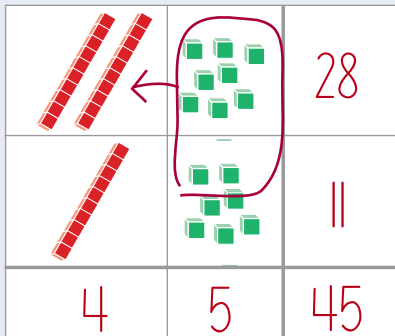

$24 + 29 = 53$

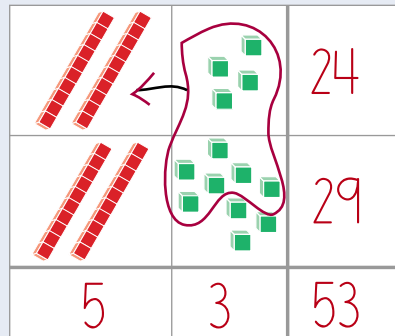

$37 + 14 = 51$

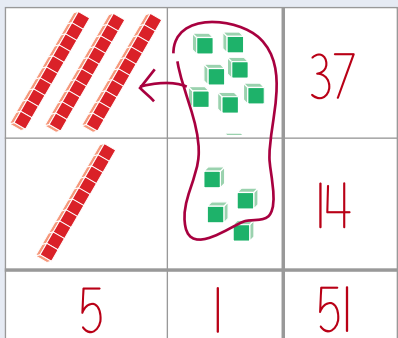

$19 + 32 = 51$

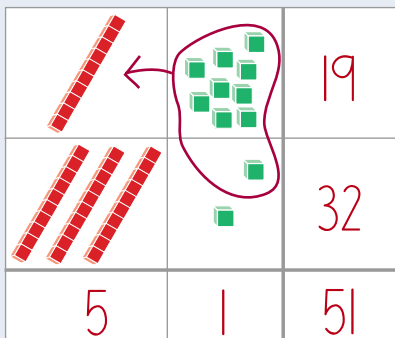

$36 + 25 = 61$

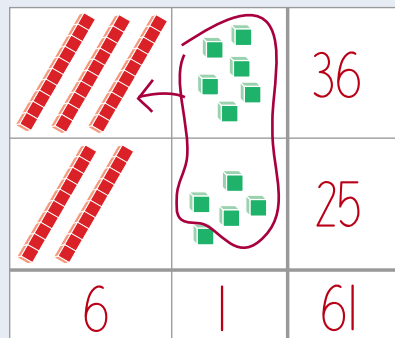

13

Tegn selv plusstykkerne

$27 + 18 = 45$

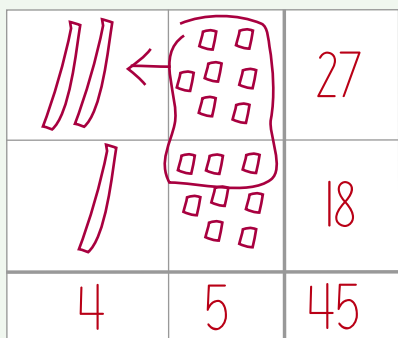

$38 + 25 = 63$

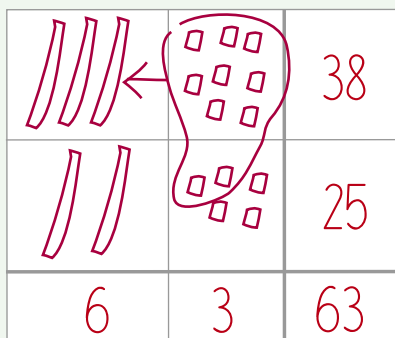

$27 + 39 = 66$

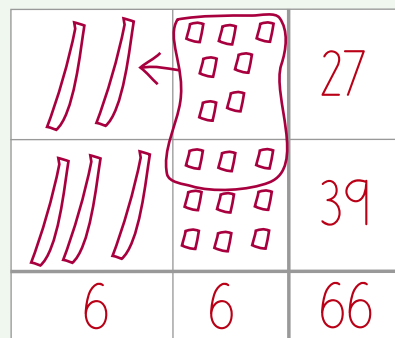

$\underline{\quad} + \underline{\quad} = 31$

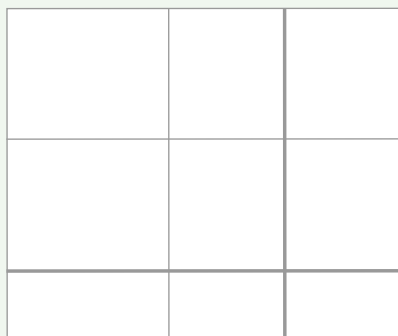

$\underline{\quad} + \underline{\quad} = 42$

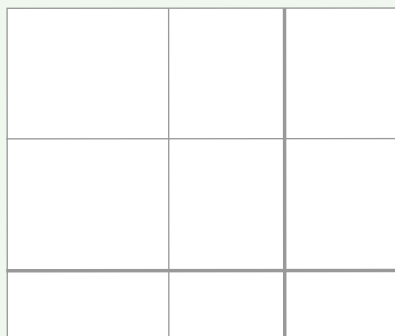

$\underline{\quad} + \underline{\quad} = 50$

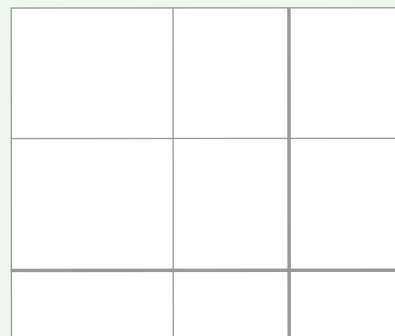

12. Regn plusstykkerne med kuberne. Denne gang skal ti enere veksles til en tier.
13. Regn plusstykkerne. Tegn selv kuberne.

Hvordan trækker man fra?



1

Hjælp Fjollede Fire og Sjove Seks



1 stk. 7 kr.
2 stk. 12 kr.

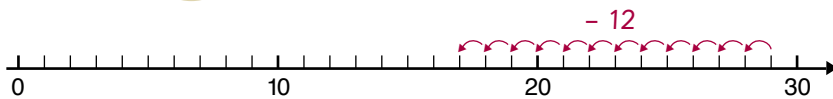

$$29 - 12 = \underline{17}$$

2

Minus

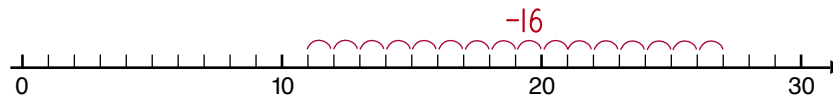

$$27 - 16 = \underline{11}$$

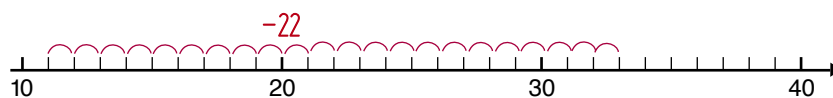

$$33 - 22 = \underline{11}$$

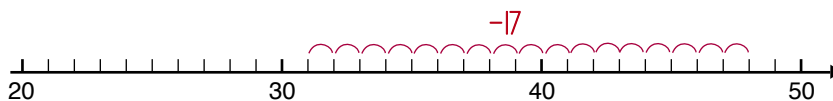

$$48 - 17 = \underline{31}$$

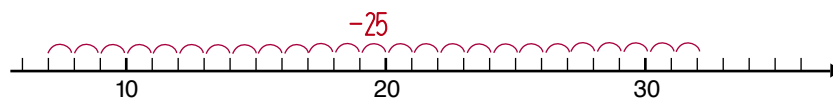

$$32 - 25 = \underline{7}$$

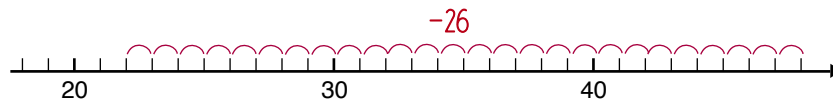

$$48 - 26 = \underline{22}$$

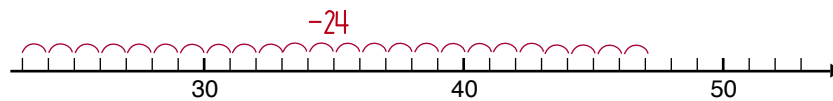

$$47 - 24 = \underline{23}$$

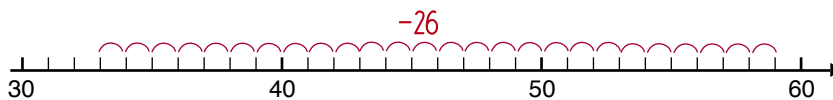

$$59 - 26 = \underline{33}$$

3

Minus

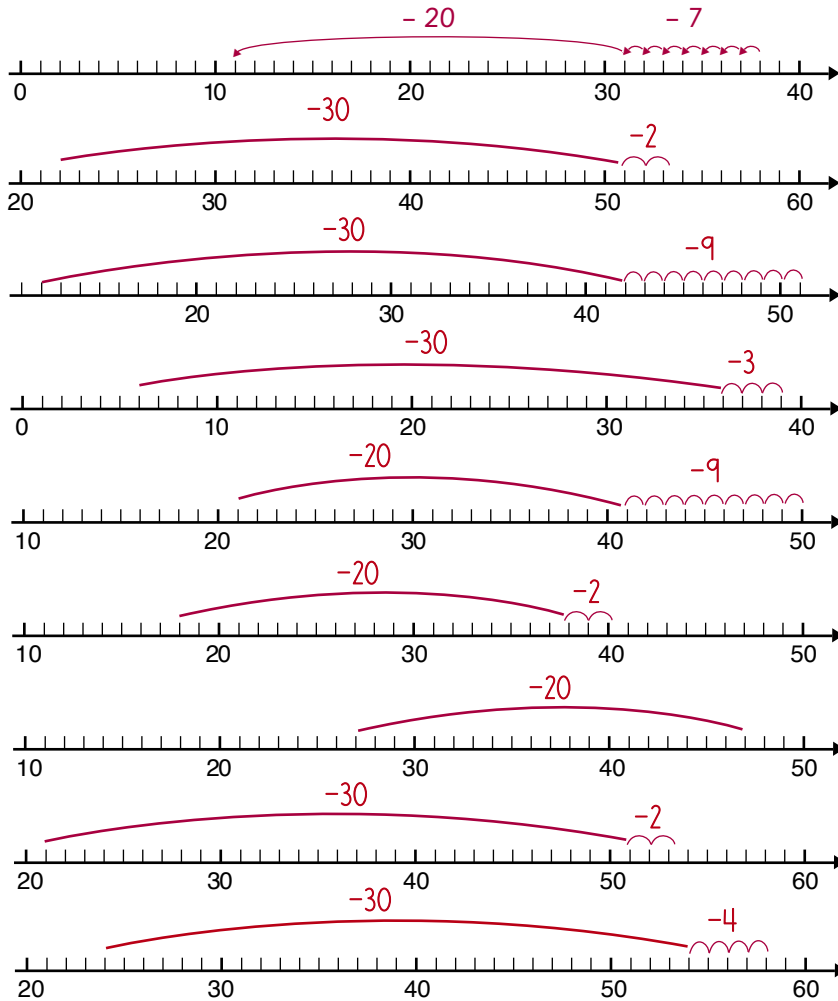

$38 - 27 = 11$

$54 - 32 = 22$

$51 - 39 = 12$

$39 - 33 = 6$

$50 - 29 = 21$

$40 - 22 = 18$

$47 - 20 = 27$

$53 - 32 = 21$

$58 - 34 = 24$

4

Plus med blå \rightarrow Minus med rød \leftarrow

$17 + 11 = 28$

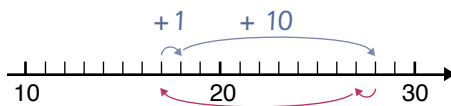

$28 - 11 = 17$

$14 + 23 = 37$

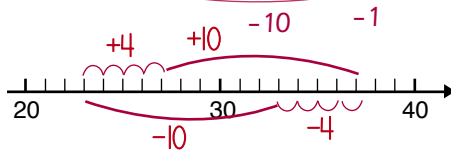

$37 - 14 = 23$

$26 + 18 = 44$

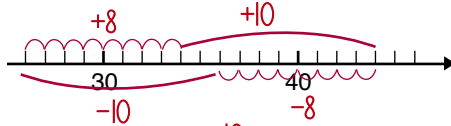

$44 - 18 = 26$

$25 + 11 = 36$

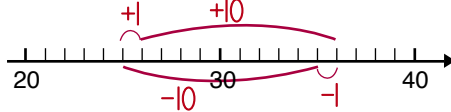

$36 - 11 = 25$

$32 + 17 = 49$

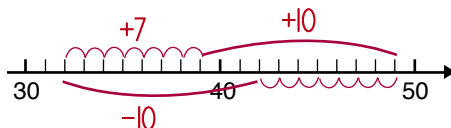

$49 - 17 = 32$

3. Regn minusstykkerne ved hjælp af tallinjen.
4. Regn plus- og minusstykkerne ved hjælp af tallinjen.

5

Minus i taltavlen

20	21	22	23	24	25	26	27	28	29
10	11	12	13	14	15	16	17	18	19
0	1	2	3	4	5	6	7	8	9

$$29 - 17 = \underline{12}$$

20	21	22	23	24	25	26	27	28	29
10	11	12	13	14	15	16	17	18	19
0	1	2	3	4	5	6	7	8	9

$$28 - 24 = \underline{4}$$

30	31	32	33	34	35	36	37	38	39
20	21	22	23	24	25	26	27	28	29
10	11	12	13	14	15	16	17	18	19

$$36 - 21 = \underline{15}$$

40	41	42	43	44	45	46	47	48	49
30	31	32	33	34	35	36	37	38	39
20	21	22	23	24	25	26	27	28	29

$$47 - 20 = \underline{27}$$

6

Plus og minus i taltavlen

$$16 + 13 = \underline{29}$$

20	21	22	23	24	25	26	27	28	29
10	11	12	13	14	15	16	17	18	19
0	1	2	3	4	5	6	7	8	9

$$\underline{29} - 13 = \underline{16}$$

$$8 + 21 = \underline{29}$$

20	21	22	23	24	25	26	27	28	29
10	11	12	13	14	15	16	17	18	19
0	1	2	3	4	5	6	7	8	9

$$\underline{29} - \underline{21} = \underline{8}$$

$$12 + 23 = \underline{35}$$

30	31	32	33	34	35	36	37	38	39
20	21	22	23	24	25	26	27	28	29
10	11	12	13	14	15	16	17	18	19

$$\underline{35} - \underline{23} = \underline{12}$$

$$17 + 21 = \underline{38}$$

30	31	32	33	34	35	36	37	38	39
20	21	22	23	24	25	26	27	28	29
10	11	12	13	14	15	16	17	18	19

$$\underline{38} - \underline{21} = \underline{17}$$

$$\underline{20} + \underline{26} = \underline{46}$$

40	41	42	43	44	45	46	47	48	49
30	31	32	33	34	35	36	37	38	39
20	21	22	23	24	25	26	27	28	29

$$46 - 26 = \underline{20}$$

7

Udfyld tallinjen og regn stykket

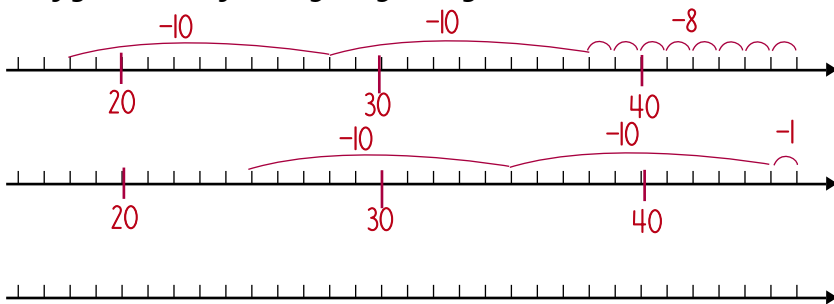

$46 - 28 = 18$

$76 - 21 = 55$

Individuel
 $\underline{\quad} - \underline{\quad} = 52$

8

Udfyld taltavlen og regn stykket

50	51	52	53	54	55	56	57	58	59
40	41	42	43	44	45	46	47	48	49
30	31	32	33	34	35	36	37	38	39

$56 - 23 = 33$

Individuel
 $\underline{\quad} - \underline{\quad} = 47$

80	81	82	83	84	85	86	87	88	89
70	71	72	73	74	75	76	77	78	79
60	61	62	63	64	65	66	67	68	69

$86 - 18 = 68$

9

Vis hvordan du regner *Eleverne vælger selv en regnemetode.*

26 - 13	35 - 21	42 - 20
13	14	22
55 - 34	75 - 25	80 - 40
21	50	40

7. Skriv tal på tallinjen og regn stykket.
 8. Skriv tal i taltavlen og regn stykket.
 9. Regn de seks minusstykker. Vis, hvordan du kom frem til resultatet.

10

Minus

$48 - 25 = \underline{23}$

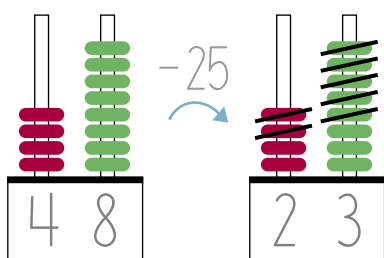

$59 - 32 = \underline{27}$

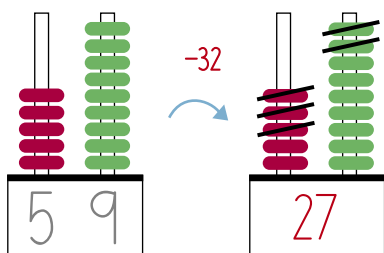

11

Minus

$56 - 31 = \underline{25}$

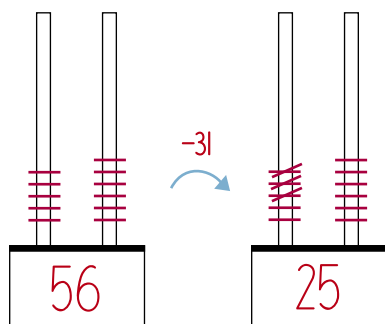

$38 - 16 = \underline{22}$

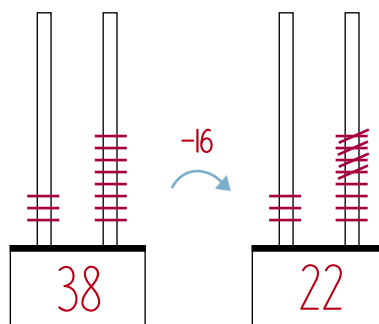

$44 - 32 = \underline{12}$

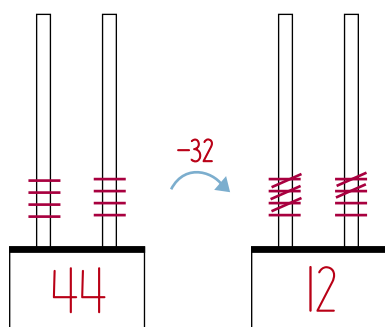

$36 - 14 = \underline{22}$

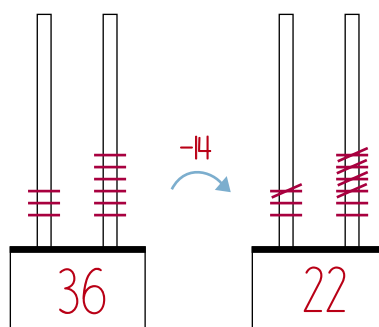

Minus med veksling

$$32 - 18 = \underline{14}$$

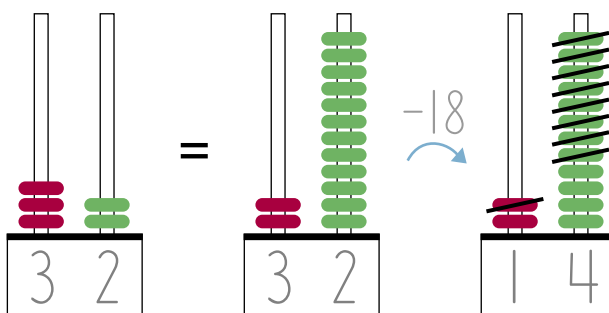

$$43 - 16 = \underline{27}$$

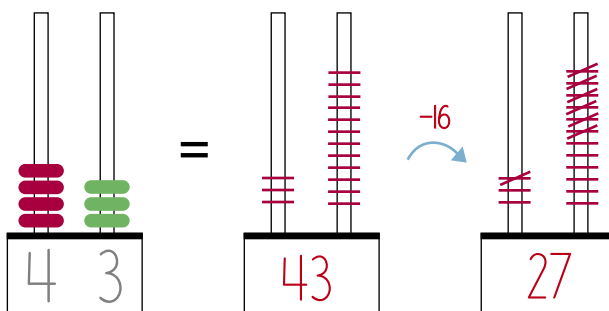

$$42 - 26 = \underline{16}$$

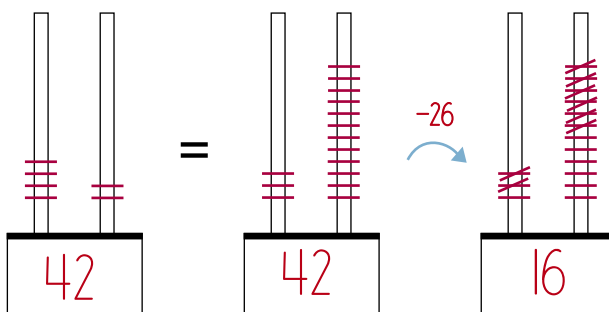

$$53 - 35 = \underline{18}$$

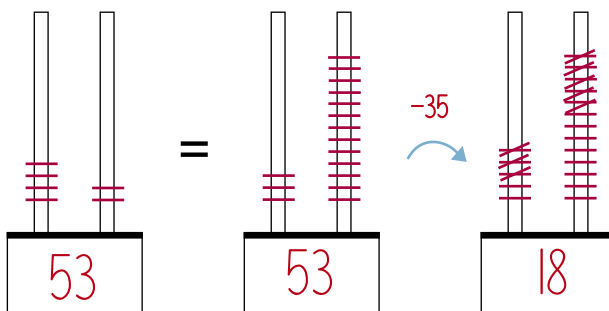

$$41 - 25 = \underline{16}$$

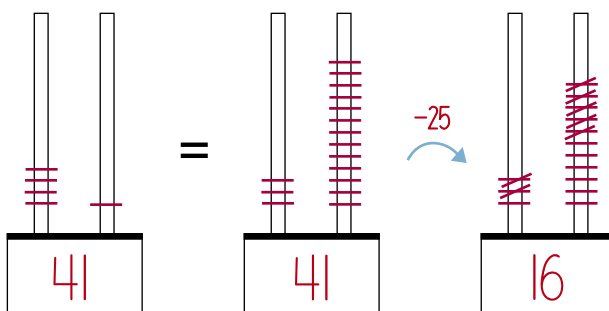

Hvor meget skal der i dejen?



1

Hvor meget af hver ting skal du bruge?

Kanelnegle

1 portion dej (til 30 stk.)

Dej:

500 g mel
1 tsk. salt
2 tsk. kardemomme
4 spsk. sukker
300 g smør
2 kopper mælk
50 g gær

Fyld:

150 g smør
100 g flormelis
3 tsk. kanel

1 portion dej (til 60 stk.)

Dej:

1000 g mel
2 tsk. salt
4 tsk. kardemomme
8 spsk. sukker
600 g smør
4 kopper mælk
100 g gær

Fyld:

300 g smør
200 g flormelis
6 tsk. kanel

Flere løsninger
1 portion dej (til ___ stk.)

Dej:

_____ g mel
_____ tsk. salt
_____ tsk. kardemomme
_____ spsk. sukker
_____ g smør
_____ kopper mælk
_____ g gær

Fyld:

_____ g smør
_____ g flormelis
_____ tsk. kanel

Kannelsneglene er i poser.
Der er 5 kannelsnegle i hver pose.

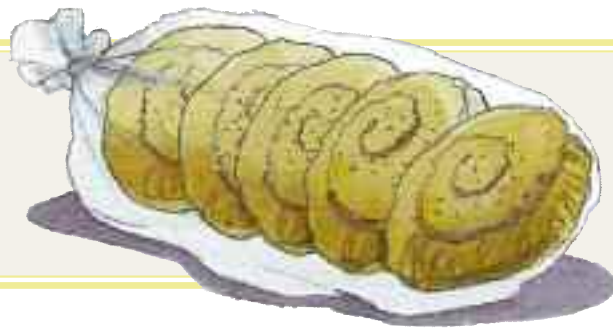

2

Hvor mange kannelsnegle?



10 kannelsnegle



15 kannelsnegle



25 kannelsnegle



40 kannelsnegle



35 kannelsnegle



50 kannelsnegle

3

Tegn poserne

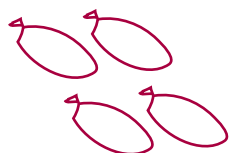

20 kannelsnegle



30 kannelsnegle

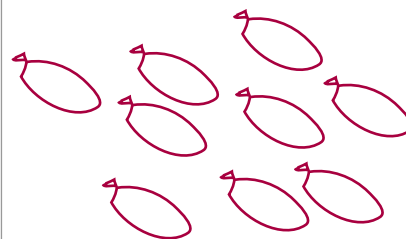

45 kannelsnegle

4

Hver kannelsnegl vejer 50 g. Hvad vejer kannelsneglene tilsammen?



100 g



200 g



250 g



500 g

2. Skriv hvor mange kannelsnegle, der er i poserne.
3. Tegn poserne, så det passer med antallet af kannelsnegle.
4. Skriv, hvad de viste kannelsnegle vejer tilsammen.

100 knapper

1000 knapper

200 KR.



2000 KR.

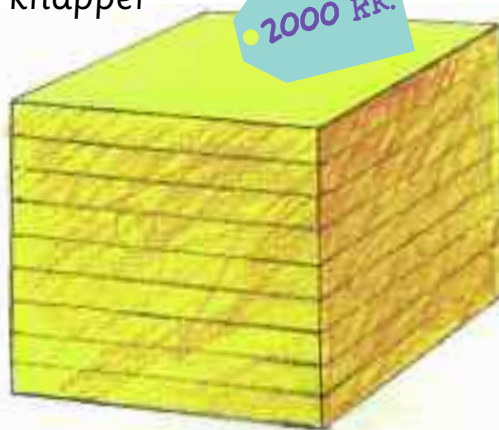

2 KR.

1 knap

20 KR.

10 knapper

5

Hvad koster knapperne?

	i alt	
1	2	kr.
2	4	kr.
3	6	kr.
4	8	kr.
5	10	kr.
6	12	kr.
7	14	kr.
8	16	kr.
9	18	kr.





	i alt	
1	20	kr.
2	40	kr.
3	60	kr.
4	80	kr.
5	100	kr.
6	120	kr.
7	140	kr.
8	160	kr.
9	180	kr.

	i alt	
1	200	kr.
2	400	kr.
3	600	kr.
4	800	kr.

	i alt	
1	2000	kr.
2	4000	kr.
5	10000	kr.
10	20000	kr.

6

Betal for ...

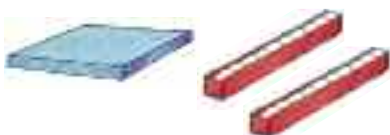
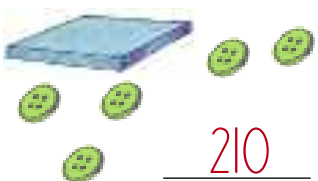
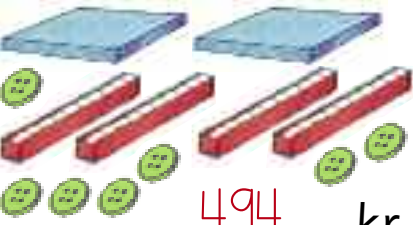
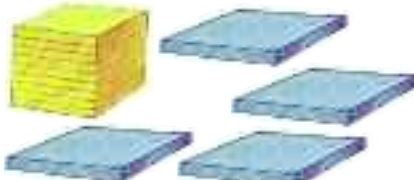
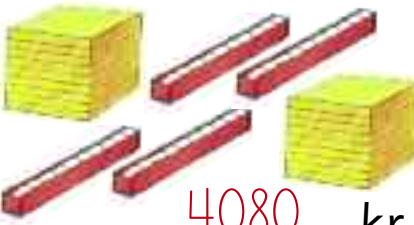
 <u>48</u> kr.	 <u>30</u> kr.	 <u>64</u> kr.
 <u>242</u> kr.	 <u>240</u> kr.	 <u>210</u> kr.
 <u>494</u> kr.	 <u>2800</u> kr.	 <u>4080</u> kr.

7

Køb for ...

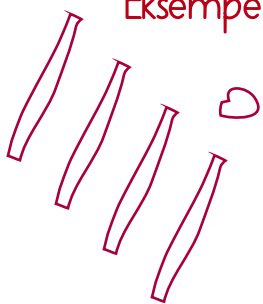
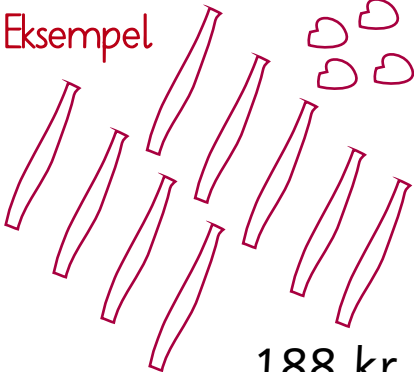
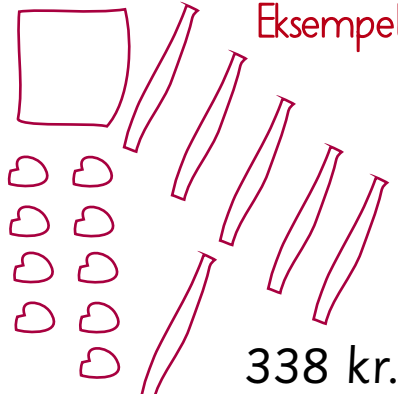
<p>Eksempel</p>  82 kr.	<p>Eksempel</p>  188 kr.	<p>Eksempel</p>  338 kr.
---	---	--

8

Køb knapper

16 knapper	32	kr.	65 knapper	130	kr.
36 knapper	72	kr.	105 knapper	210	kr.
41 knapper	82	kr.	120 knapper	240	kr.
50 knapper	100	kr.	125 knapper	250	kr.

6. Skriv, hvad de viste knapper koster.
 7. Tegn de knapper, du kan købe for de tre beløb.
 8. Regn ud, hvad det vil koste at købe de forskellige antal knapper, og udfyld skemaet.

9

Find forskellen

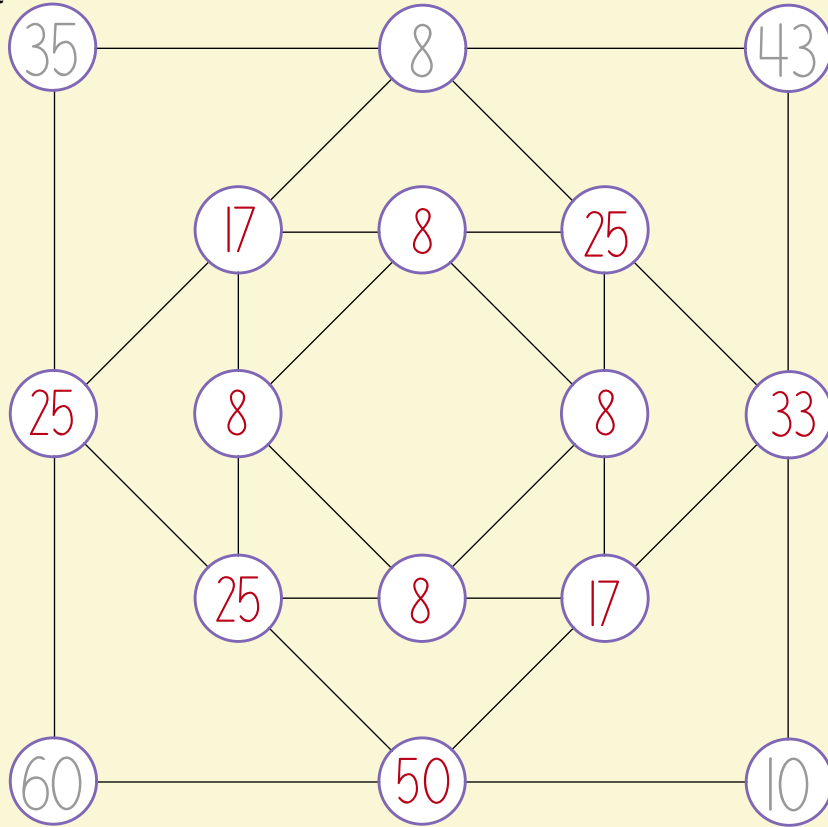

10

Plus på række *Eleverne vælger selv de tal, der tilsammen giver tallet i cirklerne*

Grid for the number 12:

	12	

Grid for the number 15:

	15	

Grid for the number 16:

	16	

Grid for the number 18:

	18		

Grid for the number 20:

	20		

11

Sum 10. Brug de viste tal

1 2 2 2 2 2 3 3 4 4

Eksempel

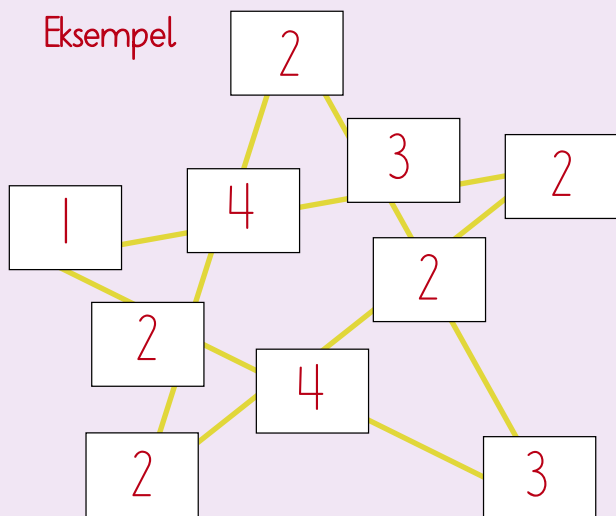
**12**

Sum 16. Brug de viste tal

2 2 2 4 4 4 4 6 6 6

Eksempel

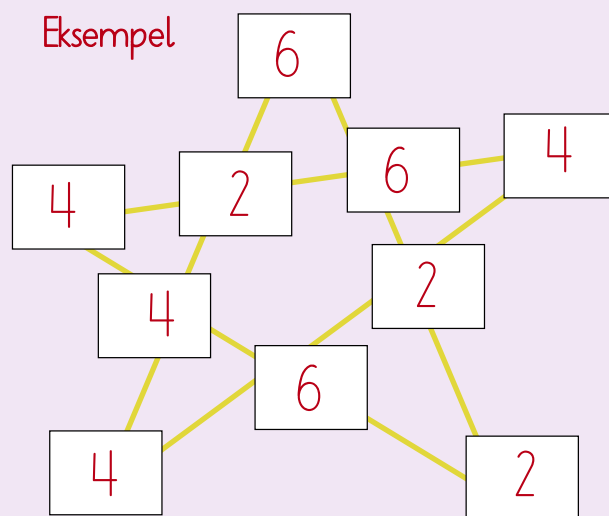
**13**

Samme sum

9

Eksempel

9	4	0	5
9	4	3	2
9	1	6	2
	9	9	9

10

Eksempel

5	3	2
4	2	4
1	5	4

11

Eksempel

6	3	2
1	7	3
4	1	6

12

Eksempel

7	2	3
1	6	5
4	4	4

13

Eksempel

8	1	4
3	6	4
2	6	5

14

Eksempel

9	2	3
4	6	4
1	6	7

14

Plus i pyramiden

Eksempel

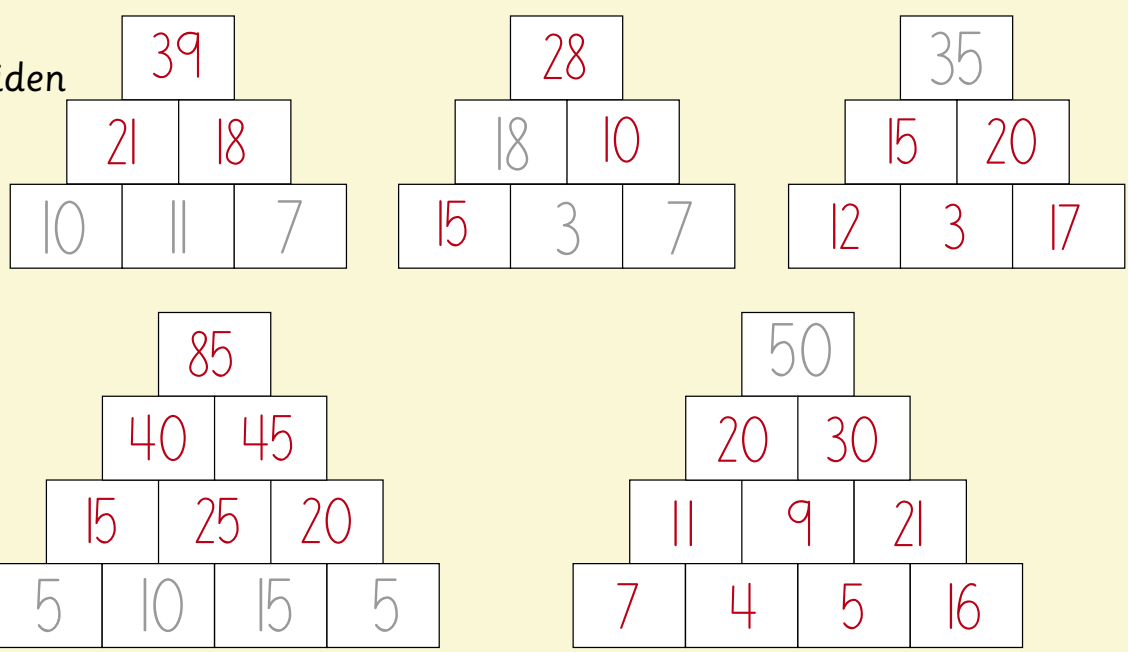

15

Minus i pyramiden

Eksempel

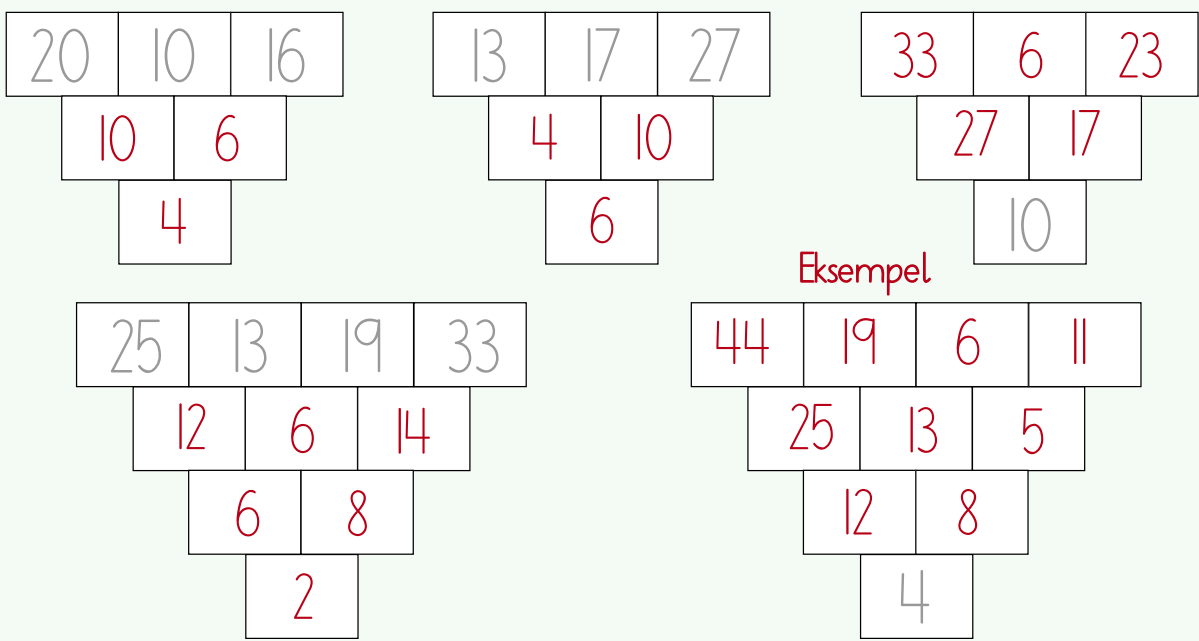

16

Plus og minus

$25 + 13 = \underline{38}$	$28 + 34 = \underline{62}$	$31 + 49 = \underline{80}$
$36 - 23 = \underline{13}$	$41 - 22 = \underline{19}$	$47 - 38 = \underline{9}$
$39 - 14 = \underline{25}$	$70 + 23 = \underline{93}$	$60 - 27 = \underline{33}$

14. Læg nabotal sammen. Resultatet skrives i feltet ovenover.
 15. Find forskellen mellem de to tal, der står ved siden af hinanden, og skriv tallet i feltet nedenunder.
 16. Regn plus- og minusstykkerne.
 ● KOPIERING FORBUDT

1

Plus

$34 + 43 = 77$ $28 + 38 = 66$ $36 + 54 = 90$

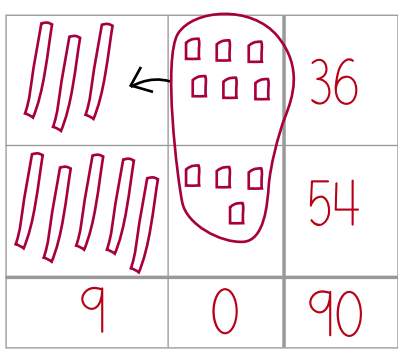
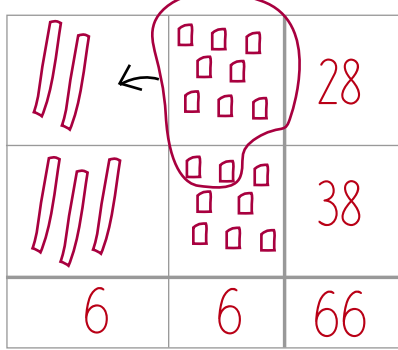
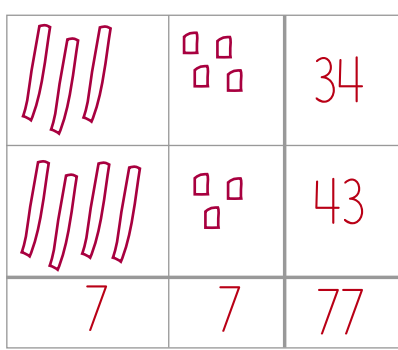

2

Minus

$78 - 33 = 45$

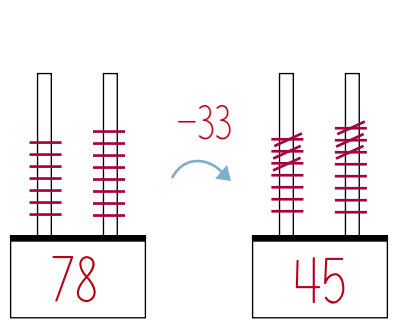

$71 - 43 = 28$

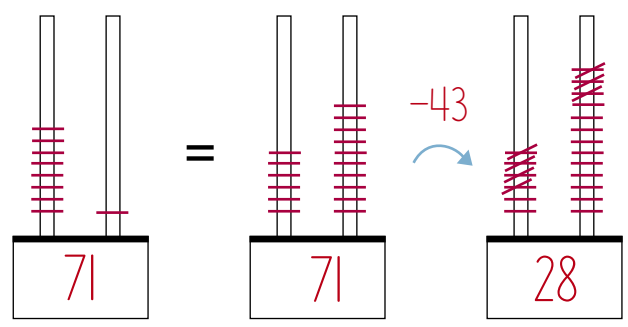

3

Hvor mange biler?

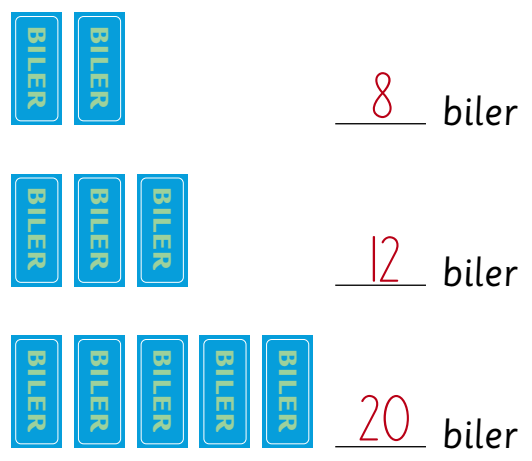

Hvad koster bilerne?

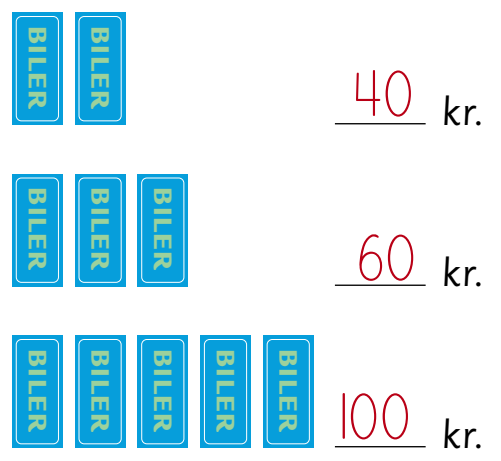

1. Regn plusstykkerne.
2. Regn minusstykkerne.
3. Skriv, hvor mange biler der er, og hvor meget bilerne koster.

Hvilken hval er den største?



Spækhugger

Længde 8 m
Vægt 8 ton
Dykketid 17 min.
Voksen 8 år
Drægtig 19 mdr.



Kaskelothval

Længde 12 m
Vægt 40 ton
Dykketid 120 min.
Voksen 9 år
Drægtig 15 mdr.



Blåhval

Længde 25 m
Vægt 125 ton
Dykketid 20 min.
Voksen 8 år
Drægtig 11 mdr.



Pukkelhval

Længde 13 m
Vægt 30 ton
Dykketid 6 min.
Voksen 5 år
Drægtig 15 mdr.



Grindehval

Længde 5 m
Vægt 3 ton
Dykketid 10 min.
Voksen 8 år
Drægtig 14 mdr.









Vågehval

Længde 9 m
Vægt 9 ton
Dykketid 20 min.
Voksen 7 år
Drægtig 12 mdr.

1

Udfyld skemaet

						
Dykketid	120 min.	17 min.	20 min.	20 min.	10 min.	6 min.
Vægt	40 ton	8 ton	9 ton	125 ton	3 ton	30 ton
Voksen	9 år	8 år	7 år	8 år	8 år	5 år
Drægtig	15 mdr.	19 mdr.	12 mdr.	11 mdr.	14 mdr.	15 mdr.
Længde	12 m	8 m	9 m	25 m	5 m	13 m

2

Tegn hvalernes længde

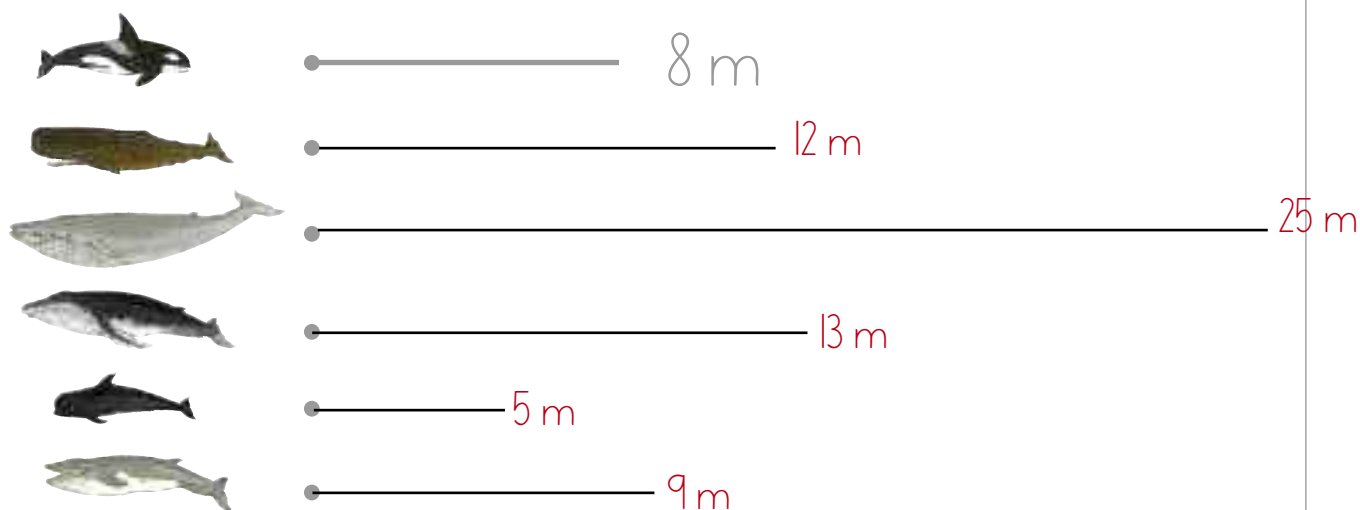
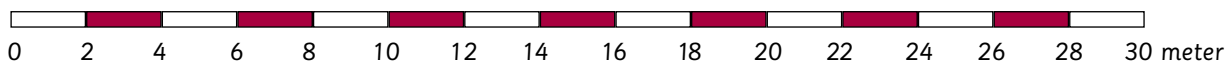

Hvor stor er forskellen på den længste og korteste hval? 20 m

3

Hvornår bliver hvalerne voksne?

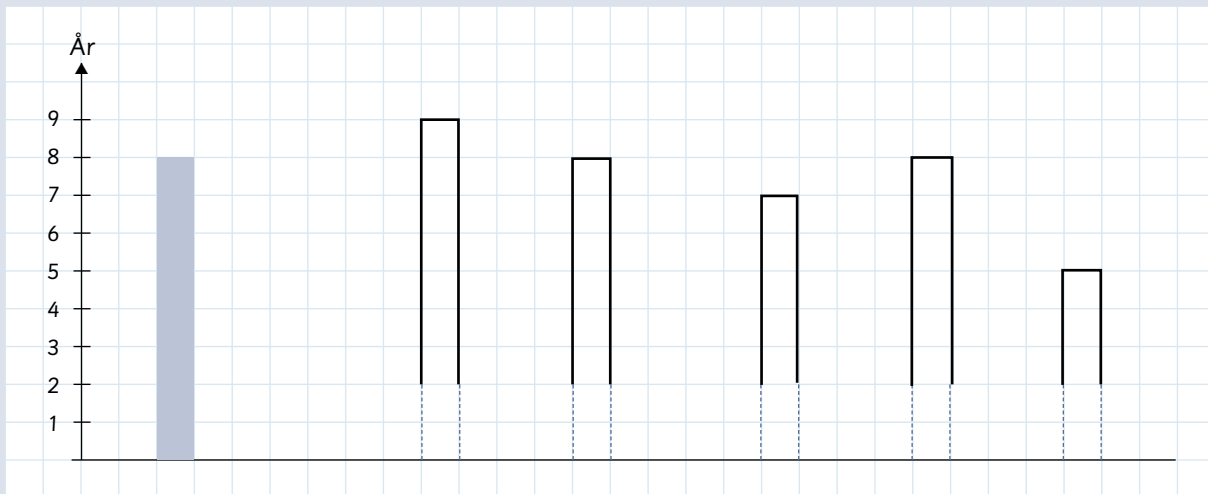

Hvilken hval bliver først voksen? Spækhugger

4



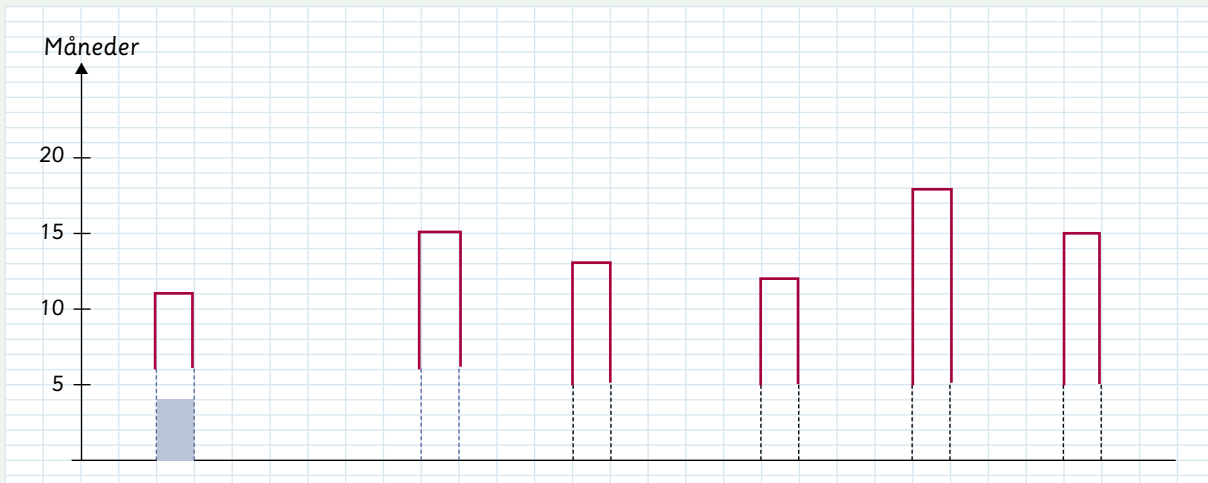









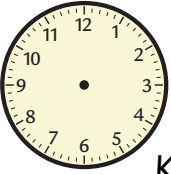



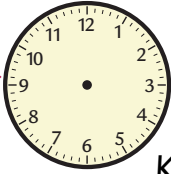

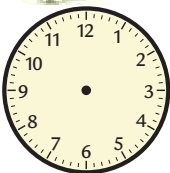

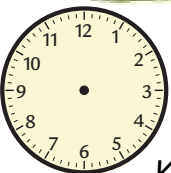

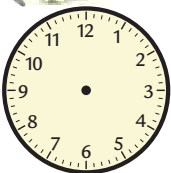
I hvor lang tid er hvalerne drægtige?

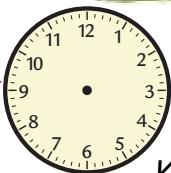

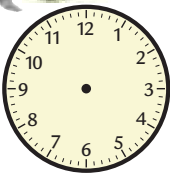
Hvilken hval er drægtig i længst tid? Spækhugger

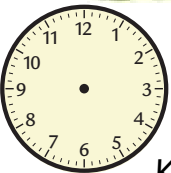
5

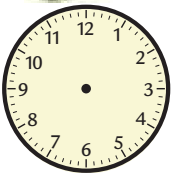
Hvor længe varer et dyk?

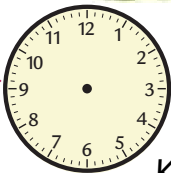
  Kl. <u>4.00/6.00</u>	 <u>20</u> min.	 Kl. <u>4.20/6.20</u>	  Kl. <u>4.20/6.00</u>	 <u>120</u> min.	 Kl. <u>6.00/8.00</u>
  Kl. _____	 <u>10</u> min.	 Kl. _____	  Kl. _____	 <u>20</u> min.	 Kl. _____
  Kl. _____	 _____ min.	 Kl. _____	  Kl. _____	 <u>17</u> min.	 Kl. _____

6

Vis dykketiden

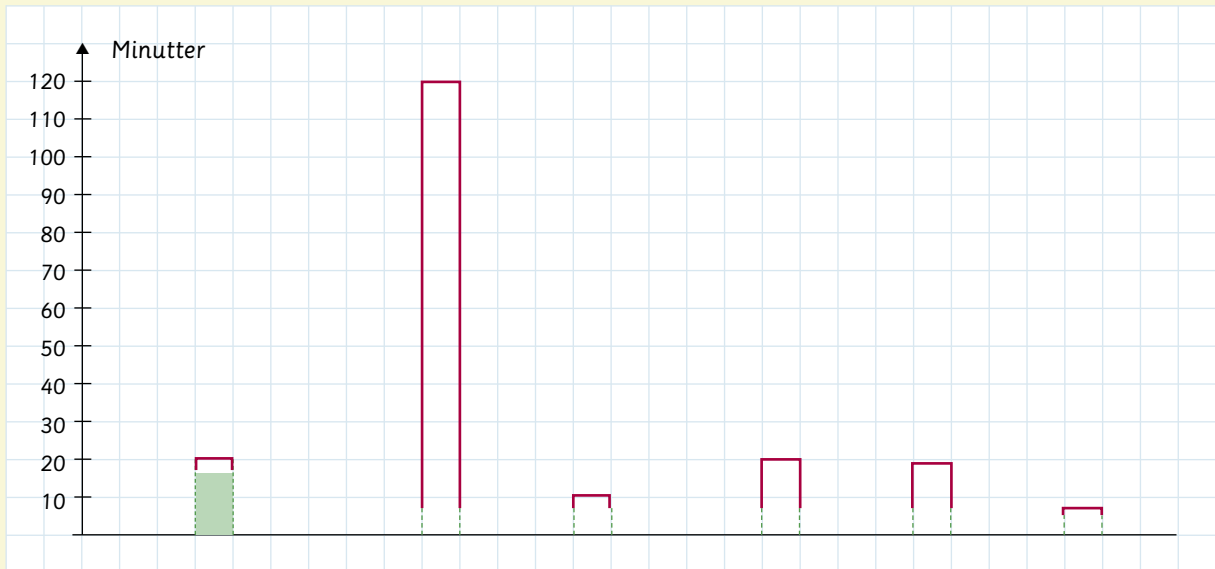

Hvilken hval kan dykke i længst tid? Kaskelothval

5. Vis dykketiden på urene. Skriv forslag til klokkeslæt.
 6. Vis dykketiden i diagrammet.

Mange besøger hvalcentret i løbet af én uge

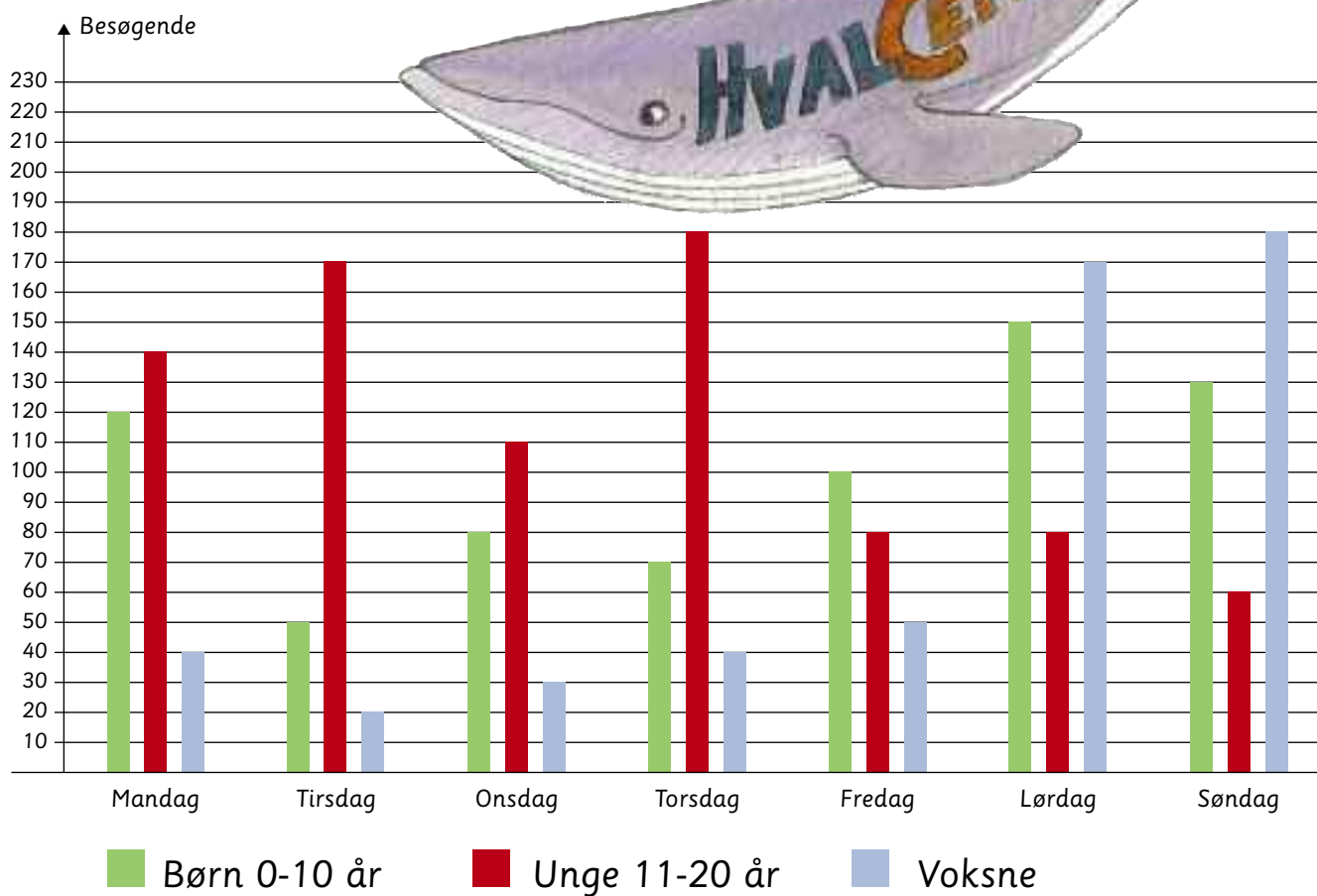
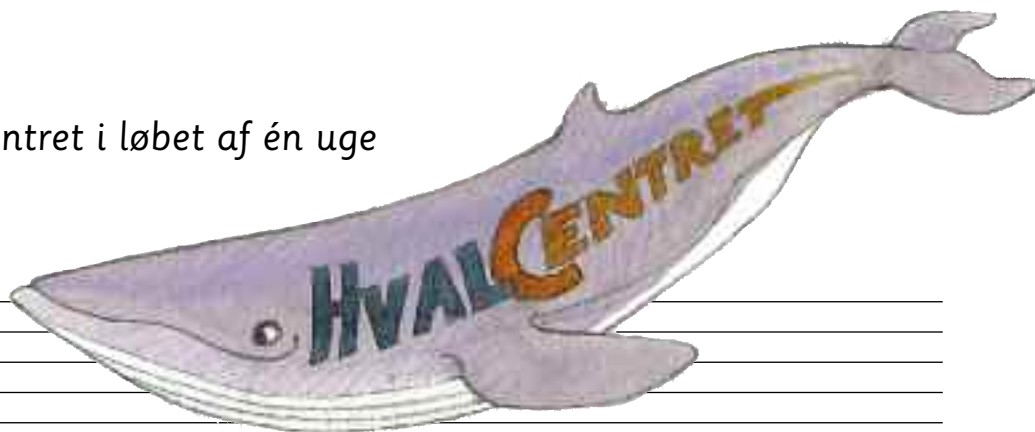

7 Udfyld skemaet

	■ Børn	■ Unge	■ Voksne
Mandag	120	140	40
Tirsdag	50	170	20
Onsdag	80	110	30
Torsdag	70	180	40
Fredag	100	80	50
Lørdag	150	80	170
Søndag	130	60	180

8

Hvor mange i alt?

Mandag	Tirsdag	Onsdag	Torsdag	Fredag	Lørdag	Søndag
300	240	220	290	230	400	370

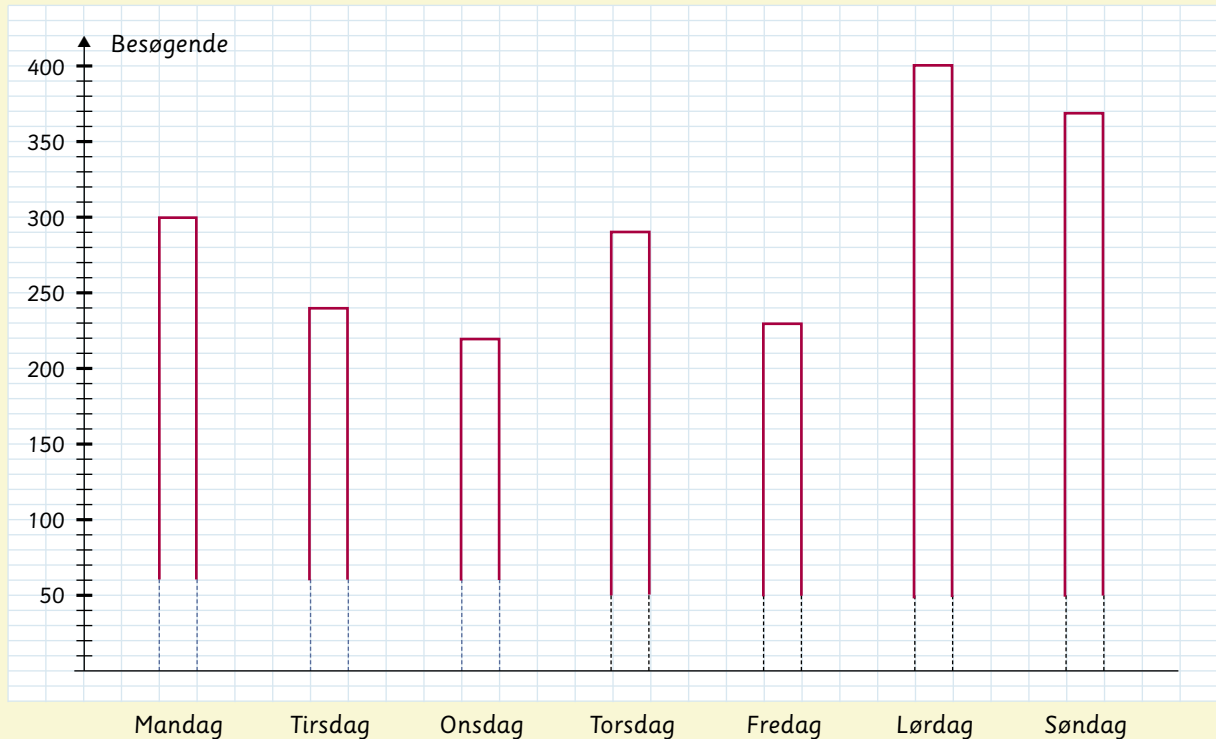

9

Hvor stor er indtægten?

BILLETPRISER

- Gratis
- 5 kr. pr. person
- 10 kr. pr. person

Indtægter – Børn og unge

Mandag	700	kr.
Onsdag	550	kr.
Lørdag	400	kr.

Indtægter – Voksne

Lørdag	Søndag
1700 kr.	1800 kr.

Indtægter – Børn, unge og voksne

Lørdag	Søndag
2100 kr.	2100 kr.

Hvilken dag tror du der er størst indtægt? Lørdag og søndag

8. Udregn det samlede antal besøgende og vis det i diagrammet.

9. Udregn billetindtægterne.

Hvor mange hvaler?

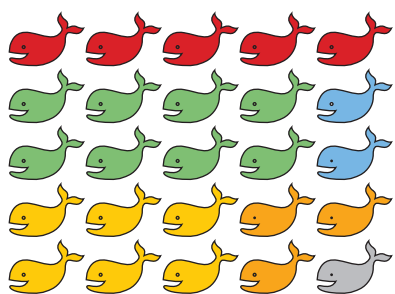

- grindehval
- spækhugger
- vågehval
- pukkelhval
- kaskelothval
- blåhval

Hvor mange hvaler har Familien Tal set i alt? _____

1

Hvor mange hvaler af hver slags?

50 hvaler

10 røde
16 grønne
12 gule

4 blå
6 orange
2 grå

100 hvaler

20 røde
32 grønne
24 gule
8 blå
12 orange
4 grå

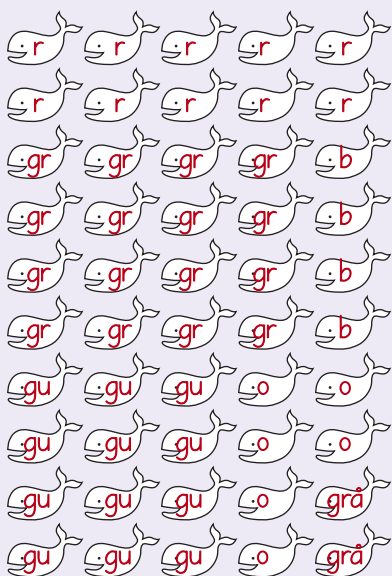

r = rød b = blå gu = gul gr = grøn o = orange grå = grå

2

Tidstabel for hvalkiggertur. Udfyld skemaet

Talby havn	9.00	12.30	16.15
Delfinstrup	9.20	12.50	16.35
Vågehavnen	9.35	13.05	16.50
Puklen	10.00	13.30	17.15
Grindehøjen	10.15	13.45	17.30
Hvalbugten	10.30	14.00	17.45
Grindehøjen	10.45	14.15	18.00
Puklen	11.00	14.30	18.15
Vågehavnen	11.25	14.55	18.40
Delfinstrup	11.40	15.10	18.55
Talby havn	12.00	15.30	19.15

Hvor lang tid tager turen? 3 timer

3

Hvad er prisen?

Eleverne vælger selv antallet af personer, når skemaet udfyldes.

PRIS

Tur/retur

50 kr.

pr. person

Antal personer	1	2	3				
Pris i kr.	50	100	150				

RABAT

Hver 10. person er

GRATIS

Antal personer	5	10	20		
Pris i kr.	250	450	900		

Hvad betaler Familien Tal? 550 kr. (12 personer)

4

Hvor mange blåhvaler?

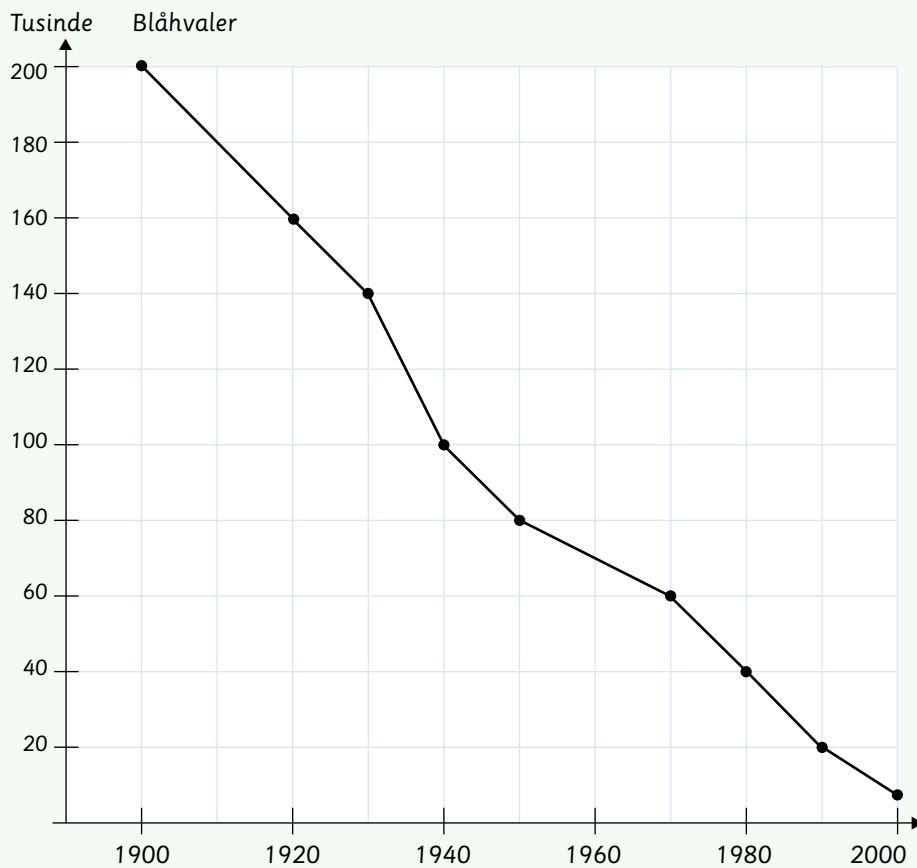

År	Blåhvaler tusinde
1900	200 tusinde
1910	180 tusinde
1920	160 tusinde
1930	140 tusinde
1940	100 tusinde
1950	80 tusinde
1960	70 tusinde
1970	60 tusinde
1980	40 tusinde
1990	20 tusinde
2000	10 tusinde

5

Hvor mange grønlandshvaler?

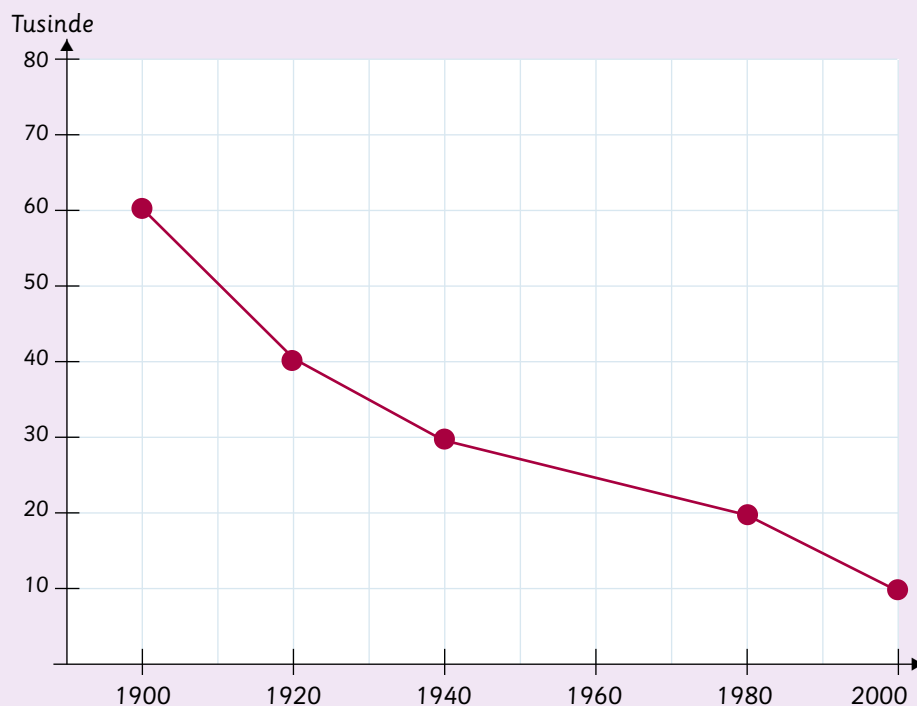







År	Grønlandshvaler tusinde
1900	60 tusinde
1920	40 tusinde
1940	30 tusinde
1980	20 tusinde
2000	10 tusinde

6

Hvor mange af hver?



Hval						
Antal	9	12	8	11	12	6

7

Vis hvor mange

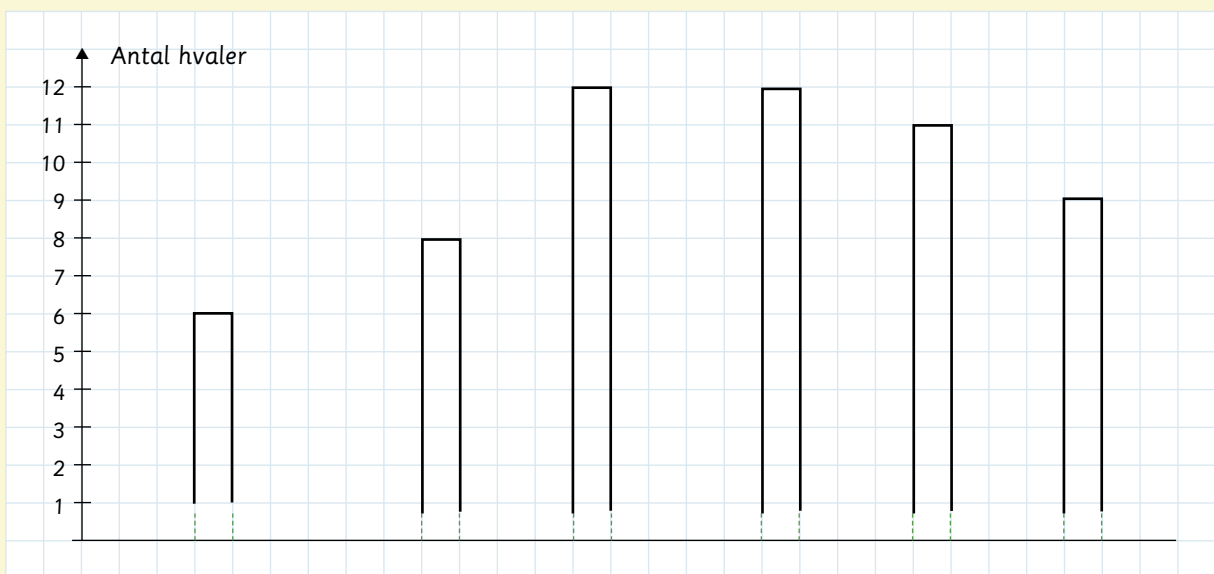

6. Skriv, hvor mange der er af hver slags hval i tabellen.
7. Vis tallene fra tabellen i et diagram.

146

147

148

149

150

1

Hvor mange i alt i år 2000?

Navn	Julie	Mikkel	Sara	Emil	Cecilie	Mads	Sofie	Mathias	Emma	Rasmus
Antal	960	1000	980	920	880	1030	940	1100	860	950

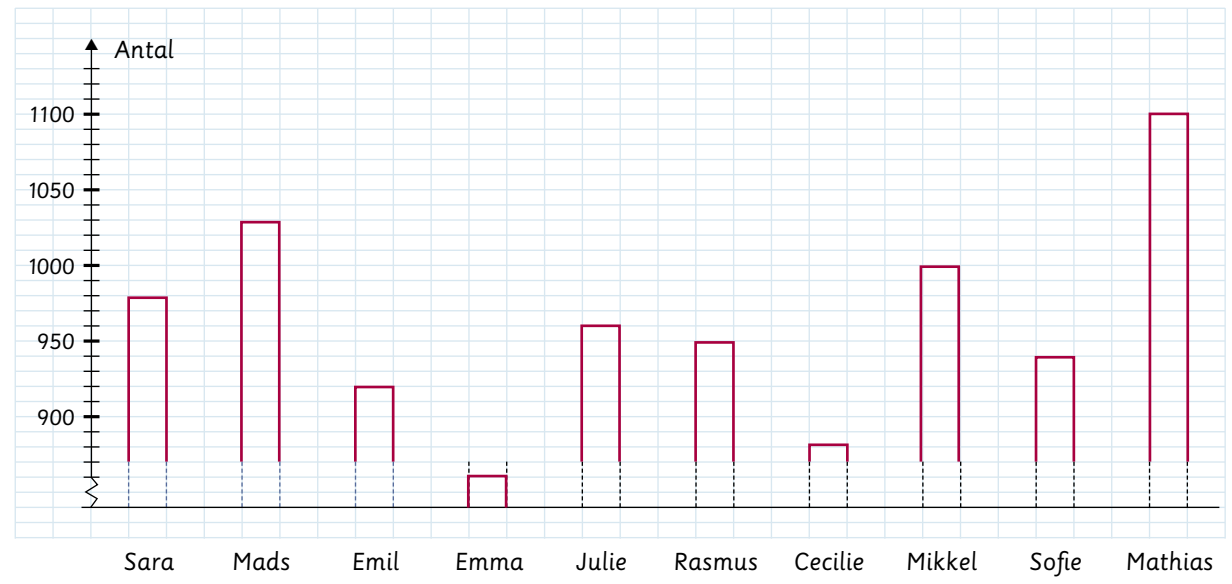

2

Hvor mange fik navnet Ida eller Rikke i årene 1990-1999?

Årstal	1990	1991	1992	1993	1994	1995	1996	1997	1998	1999
Ida ●	310	320	330	380	420	500	480	550	530	550
Rikke ●	480	510	510	490	580	530	450	430	350	270

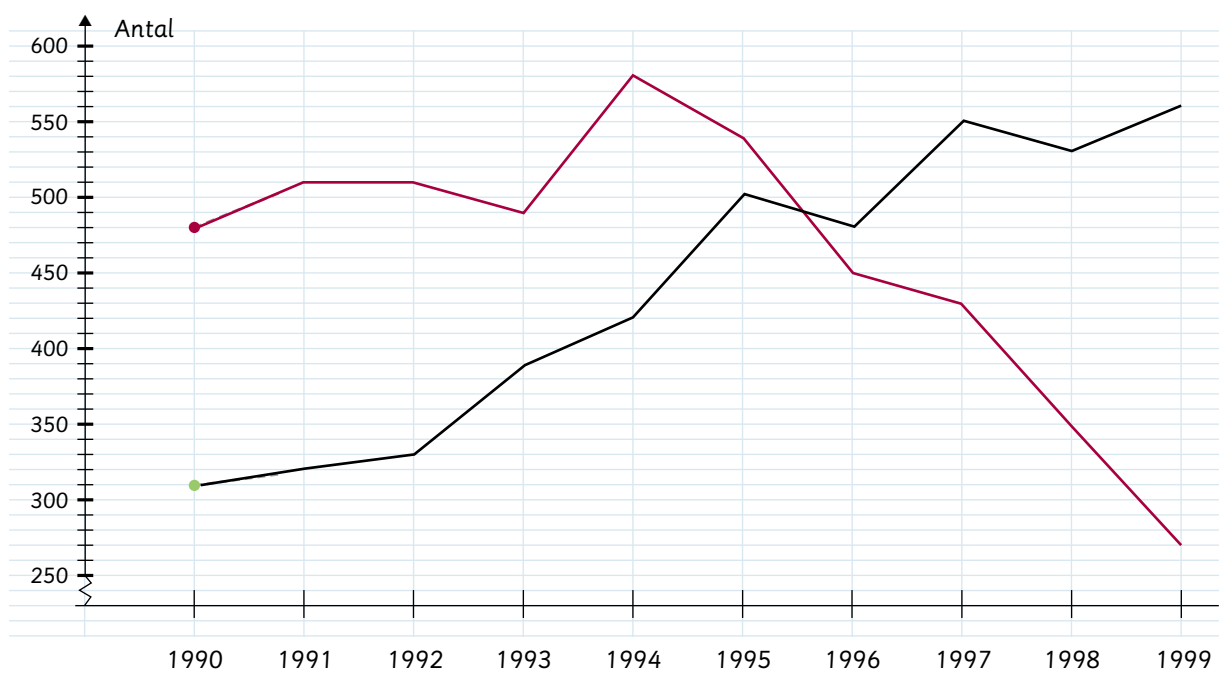

1. Vis fordelingen af navnene i søjlediagrammet. Navnene er de ti mest populære drenge- og pigenavne i år 2000.
 2. Tegn graferne for navnene Ida og Rikke i årene 1990-1999.